

3D-FEM in Fortran

Steady State Heat Conduction

Kengo Nakajima
RIKEN R-CCS

3D Steady-State Heat Conduction

$$\frac{\partial}{\partial x} \left(\lambda \frac{\partial T}{\partial x} \right) + \frac{\partial}{\partial y} \left(\lambda \frac{\partial T}{\partial y} \right) + \frac{\partial}{\partial z} \left(\lambda \frac{\partial T}{\partial z} \right) + \dot{Q}(x, y, z) = 0$$

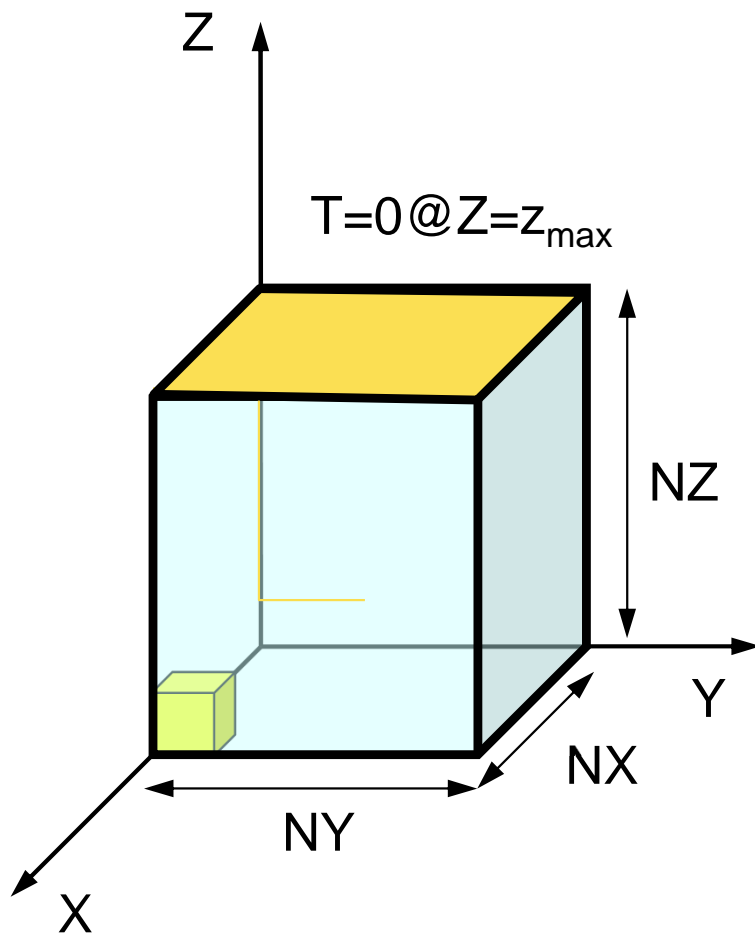

- Heat Generation
- Uniform thermal conductivity λ
- HEX meshes
 - 1x1x1 cubes
 - NX, NY, NZ cubes in each direction
- Boundary Conditions
 - T=0 @ Z=z_{max}
- Heat Gen. Rate is a function of location (cell center: x_c, y_c)
 - $\dot{Q}(x, y, z) = QVOL|x_c + y_c|$

3D Steady-State Heat Conduction

$$\frac{\partial}{\partial x} \left(\lambda \frac{\partial T}{\partial x} \right) + \frac{\partial}{\partial y} \left(\lambda \frac{\partial T}{\partial y} \right) + \frac{\partial}{\partial z} \left(\lambda \frac{\partial T}{\partial z} \right) + \dot{Q}(x, y, z) = 0$$

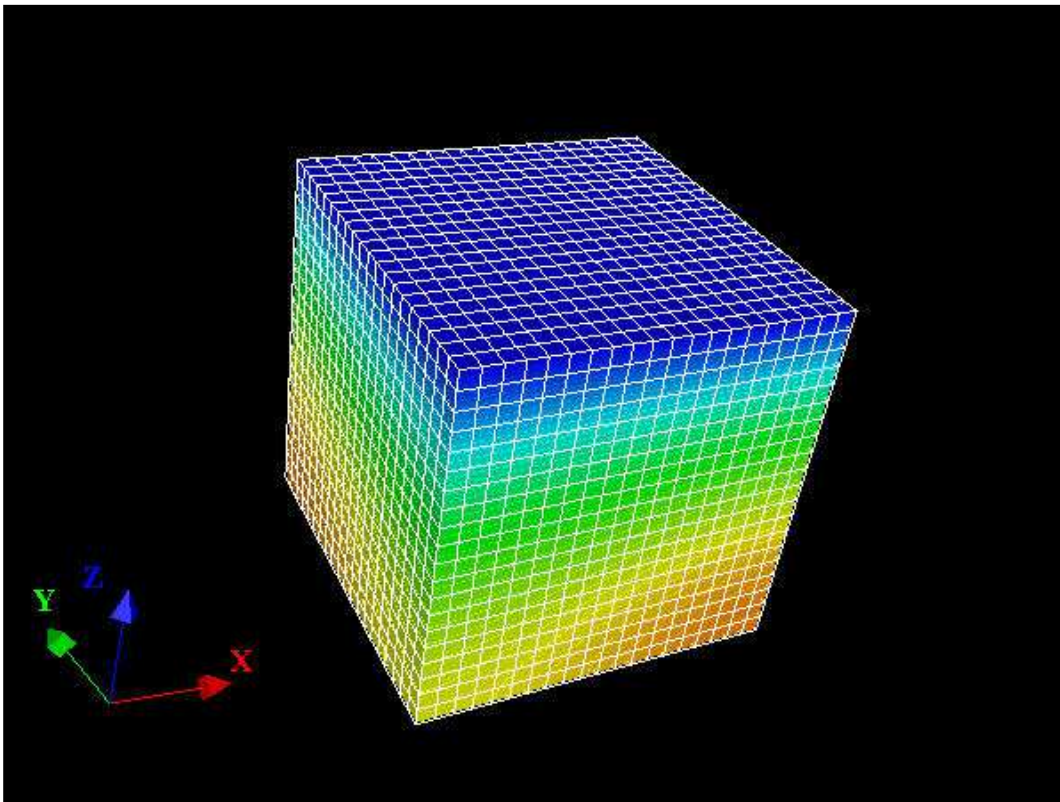

- Higher temperature at nodes far from the origin.
- Heat Gen. Rate is a function of location (cell center: x_c, y_c)

$$\dot{Q}(x, y, z) = |x_c + y_c|$$

movie

Finite-Element Procedures

- Governing Equations
- Galerkin Method: Weak Form
- Element-by-Element Integration
 - Element Matrix
- Global Matrix
- Boundary Conditions
- Linear Solver

FEM Procedures: Program

- Initialization
 - Control Data
 - Node, Connectivity of Elements (N: Node#, NE: Elem#)
 - Initialization of Arrays (Global/Element Matrices)
 - Element-Global Matrix Mapping (Index, Item)
- Generation of Matrix
 - Element-by-Element Operations (do icel= 1, NE)
 - Element matrices
 - Accumulation to global matrix
 - Boundary Conditions
- Linear Solver
 - Conjugate Gradient Method

- Formulation of 3D Element
- 3D Heat Equations
 - Galerkin Method
 - Element Matrices
- Running the Code
- Data Structure
- Overview of the Program

Extension to 2D Prob.: Triangles

三角形要素

- Triangles can handle arbitrarily shaped object
- “Linear” triangular elements provide low accuracy, therefore they are not used in practical applications.

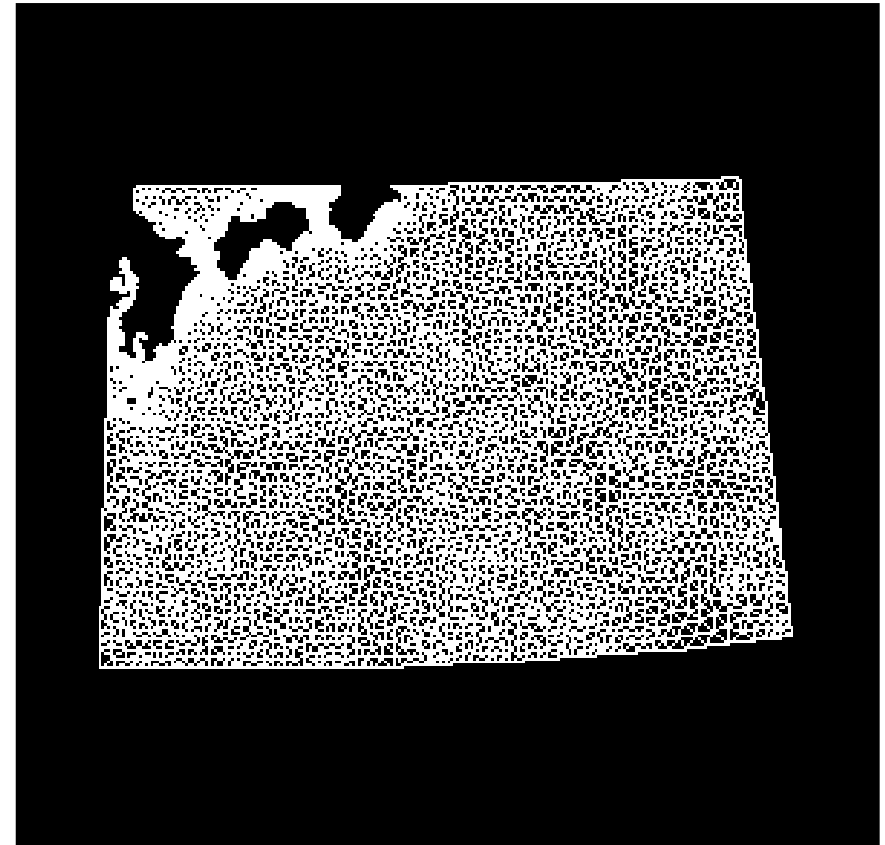
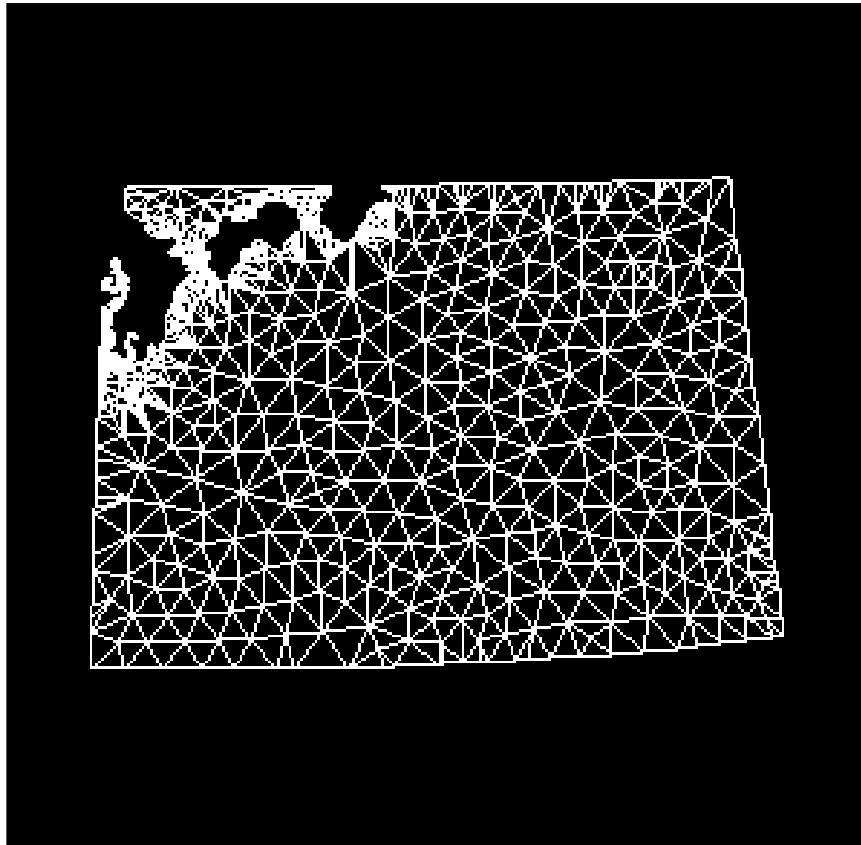

Extension to 2D Prob.: Quadrilaterals

四角形要素

- Formulation of quad. elements is possible if same shape functions in 1D elements are applied along X- and Y- axis.
 - More accurate than triangles
- Each edge must be “parallel” with X- and Y- axis.
 - Similar to FDM

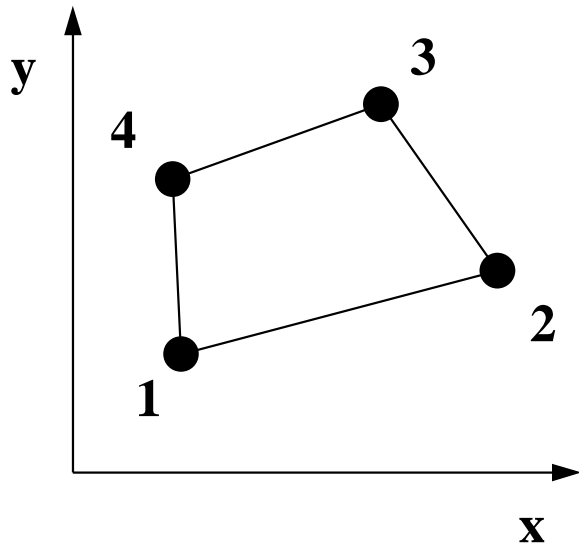

- This type of elements cannot be considered.

Natural/Local/Element Coordinate (1/2)

自然/局所/要素座標系

- Each element is mapped to square element $[\pm 1, \pm 1]$ on natural/local/element coordinate (ξ, η)

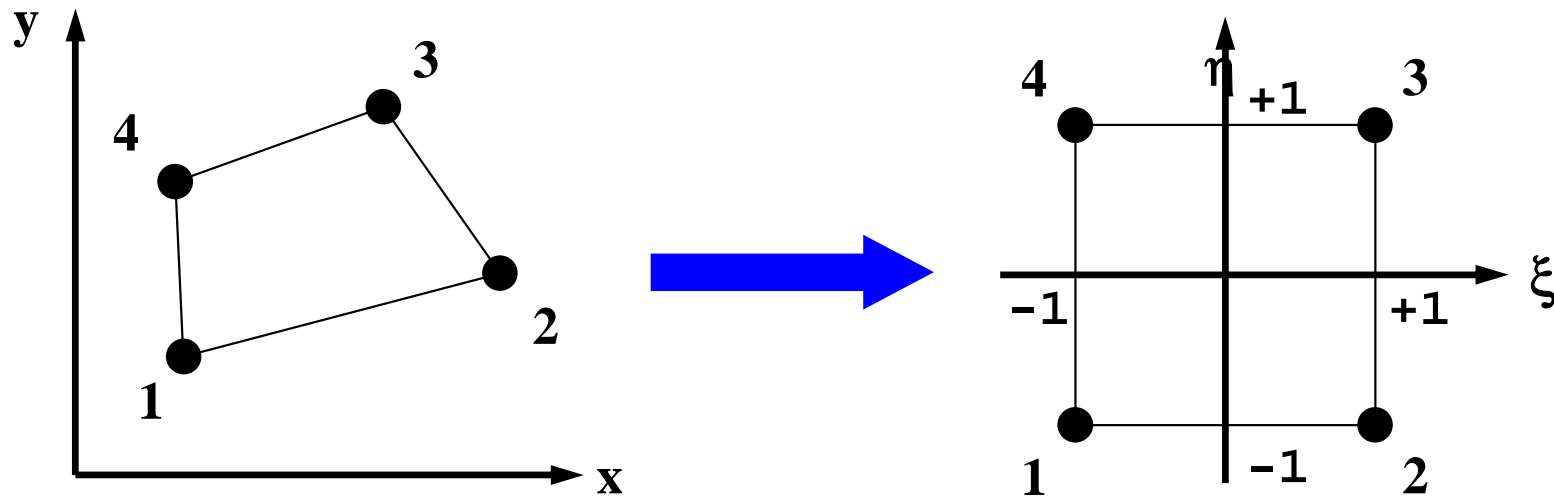

- Components of global coordinate system of each node (x, y) for certain kinds of elements are defined by shape functions $[N]$ on natural/local coordinate system, where shape functions $[N]$ are also used for interpolation of dependent variables.

Natural/Local/Element Coordinate (2/2)

自然/局所/要素座標系

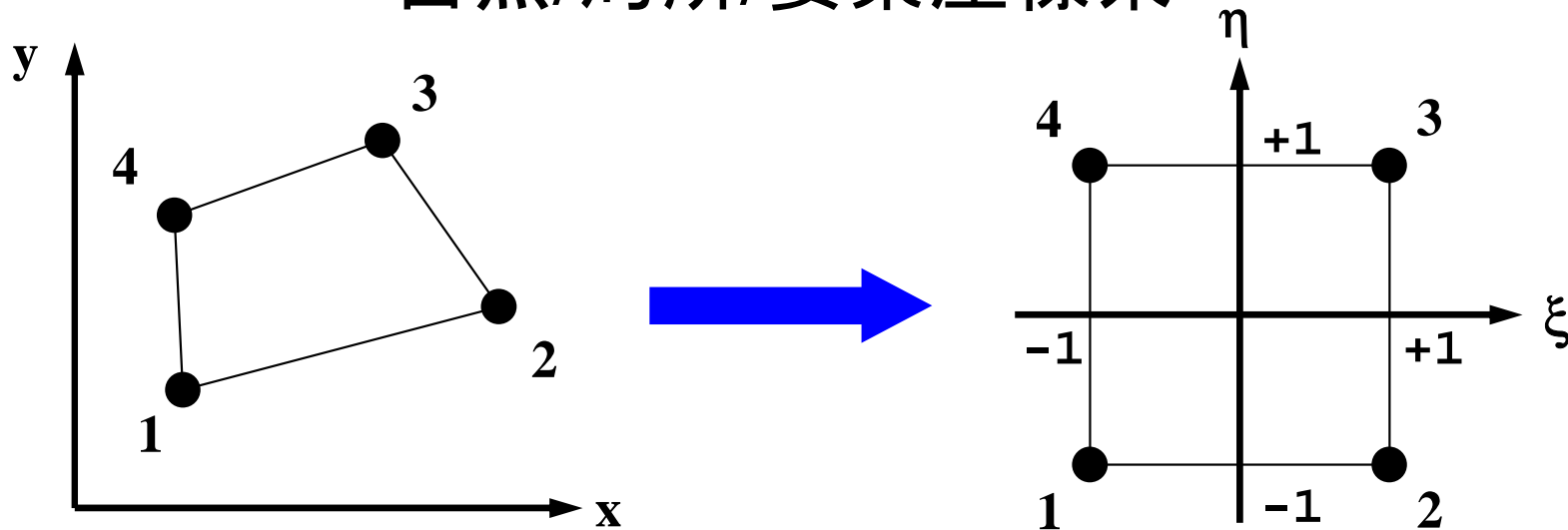

- Coordinate of each node: (x_1, y_1) , (x_2, y_2) , (x_3, y_3) , (x_4, y_4)
- Temperature at each node: T_1, T_2, T_3, T_4

$$T = \sum_{i=1}^4 N_i(\xi, \eta) \cdot T_i, \quad x = \sum_{i=1}^4 N_i(\xi, \eta) \cdot x_i, \quad y = \sum_{i=1}^4 N_i(\xi, \eta) \cdot y_i$$

- **Isoparametric Elements: N_i for (x_i, y_i) and N_i for T_i are same**

Isoparametric Element

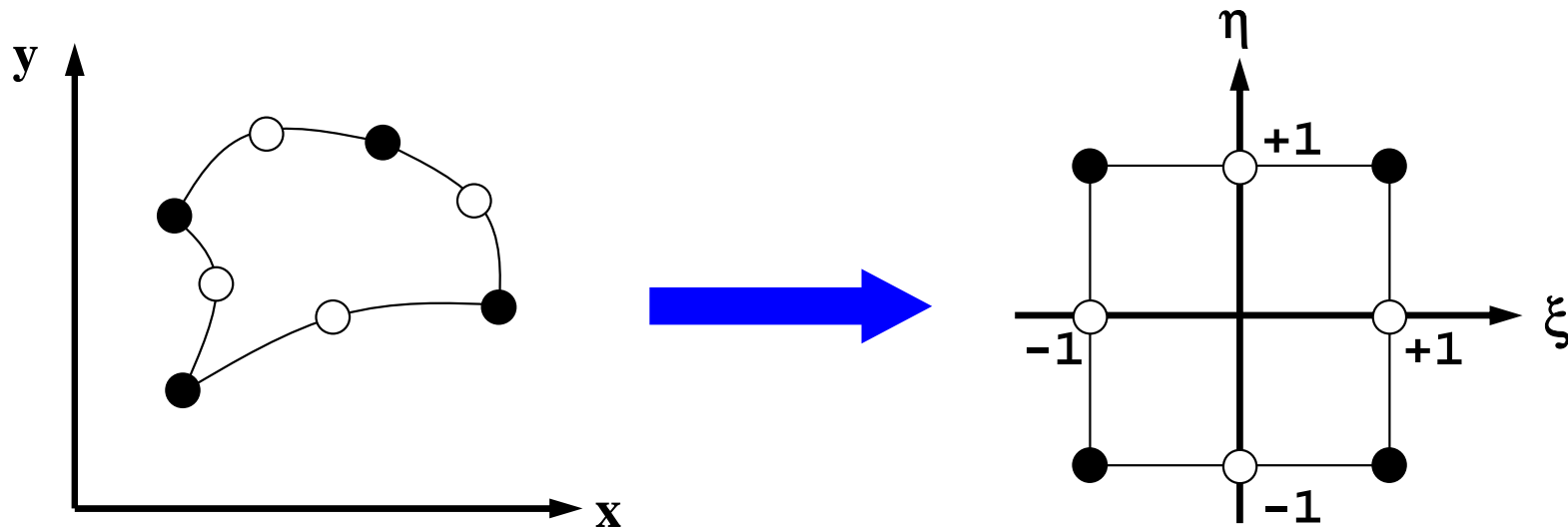

- Higher-order shape function can handle curved lines/surfaces.
- “Natural” coordinate system
- Super-Parametric: Higher-Order N_i for (x,y)
- Sub-Parametric: Lower-Order N_i for (x,y)

Shape Fn's on 2D Natural Coord. (1/3)

- Polynomial shape functions on squares of natural coordinate:

$$T = \alpha_1 + \alpha_2 \xi + \alpha_3 \eta + \alpha_4 \xi \eta$$

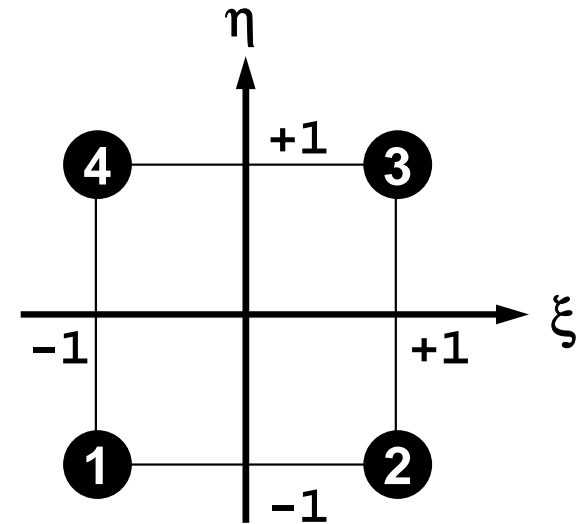

- Coefficients are calculated as follows:

$$\alpha_1 = \frac{T_1 + T_2 + T_3 + T_4}{4}, \quad \alpha_2 = \frac{-T_1 + T_2 + T_3 - T_4}{4},$$

$$\alpha_3 = \frac{-T_1 - T_2 + T_3 + T_4}{4}, \quad \alpha_4 = \frac{T_1 - T_2 + T_3 - T_4}{4}$$

Shape Fn's on 2D Natural Coord. (2/3)

$$\begin{aligned}
 T &= \alpha_1 + \alpha_2 \xi + \alpha_3 \eta + \alpha_4 \xi \eta \\
 &= \frac{T_1 + T_2 + T_3 + T_4}{4} + \frac{-T_1 + T_2 + T_3 - T_4}{4} \xi + \\
 &\quad \frac{-T_1 - T_2 + T_3 + T_4}{4} \eta + \frac{T_1 - T_2 + T_3 - T_4}{4} \xi \eta \\
 &= \frac{1}{4} (1 - \xi - \eta + \xi \eta) T_1 + \frac{1}{4} (1 + \xi - \eta - \xi \eta) T_2 + \\
 &\quad \frac{1}{4} (1 + \xi + \eta + \xi \eta) T_3 + \frac{1}{4} (1 - \xi + \eta - \xi \eta) T_4 \\
 &= \frac{1}{4} (1 - \xi)(1 - \eta) T_1 + \frac{1}{4} (1 + \xi)(1 - \eta) T_2 + \\
 &\quad \frac{1}{4} (1 + \xi)(1 + \eta) T_3 + \frac{1}{4} (1 - \xi)(1 + \eta) T_4
 \end{aligned}$$

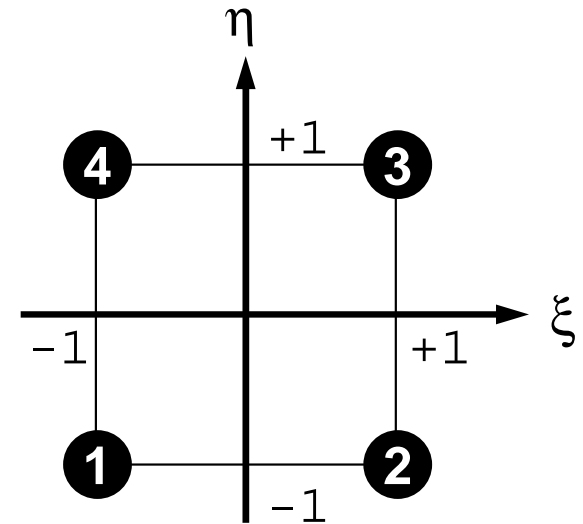

Shape Fn's on 2D Natural Coord. (2/3)

$$\begin{aligned}
 T &= \alpha_1 + \alpha_2 \xi + \alpha_3 \eta + \alpha_4 \xi \eta \\
 &= \frac{T_1 + T_2 + T_3 + T_4}{4} + \frac{-T_1 + T_2 + T_3 - T_4}{4} \xi + \\
 &\quad \frac{-T_1 - T_2 + T_3 + T_4}{4} \eta + \frac{T_1 - T_2 + T_3 - T_4}{4} \xi \eta \\
 &= \frac{1}{4} (1 - \xi - \eta + \xi \eta) T_1 + \frac{1}{4} (1 + \xi - \eta - \xi \eta) T_2 + \\
 &\quad \frac{1}{4} (1 + \xi + \eta + \xi \eta) T_3 + \frac{1}{4} (1 - \xi + \eta - \xi \eta) T_4
 \end{aligned}$$

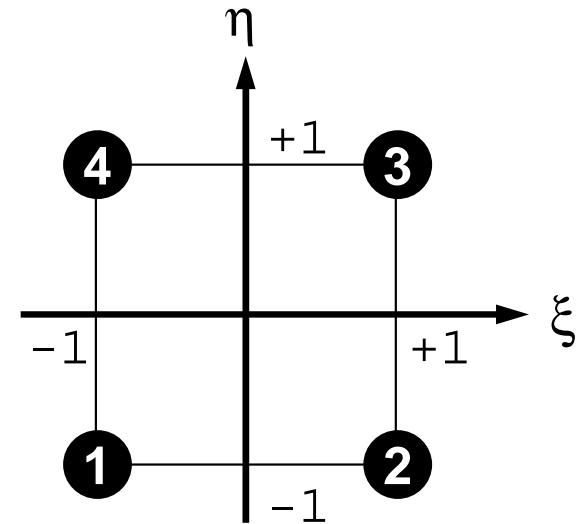

$$\begin{aligned}
 N_1 &= \frac{1}{4} (1 - \xi)(1 - \eta) T_1 + \frac{1}{4} (1 + \xi)(1 - \eta) T_2 + \\
 N_3 &= \frac{1}{4} (1 + \xi)(1 + \eta) T_3 + \frac{1}{4} (1 - \xi)(1 + \eta) T_4
 \end{aligned}$$

Shape Fn's on 2D Natural Coord. (3/3)

- T is defined as follows according to T_i :

$$T = N_1 T_1 + N_2 T_2 + N_3 T_3 + N_4 T_4$$

- Shape functions N_i :

$$N_1(\xi, \eta) = \frac{1}{4}(1-\xi)(1-\eta), \quad N_2(\xi, \eta) = \frac{1}{4}(1+\xi)(1-\eta),$$

$$N_3(\xi, \eta) = \frac{1}{4}(1+\xi)(1+\eta), \quad N_4(\xi, \eta) = \frac{1}{4}(1-\xi)(1+\eta)$$

- Also known as “bi-linear” interpolation
- Calculate N_i at each node

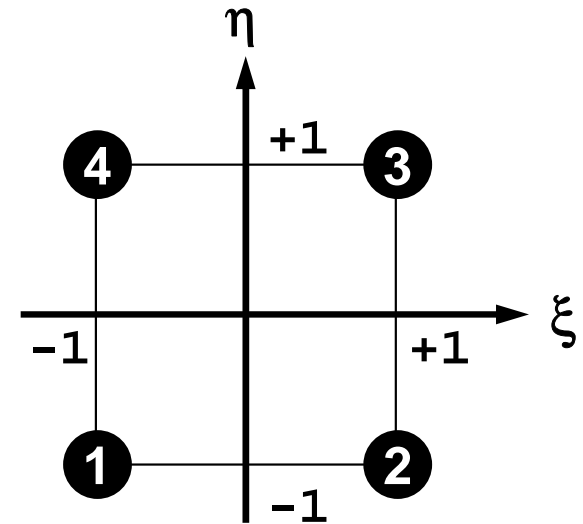

Extension to 3D Problems

- Tetrahedron/Tetrahedra (四面体) : Triangles in 2D
 - can handle arbitrary shape objects
 - Linear elements are generally less accurate, not practical
 - Higher-order tetrahedral elements are widely used.
- In this class, “tri-linear” hexahedral elements (isoparametric) are used (六面体要素)

Shape Fn's: 3D Natural/Local Coord.

$$N_1(\xi, \eta, \zeta) = \frac{1}{8}(1-\xi)(1-\eta)(1-\zeta) \quad N_5(\xi, \eta, \zeta) = \frac{1}{8}(1-\xi)(1-\eta)(1+\zeta)$$

$$N_2(\xi, \eta, \zeta) = \frac{1}{8}(1+\xi)(1-\eta)(1-\zeta) \quad N_6(\xi, \eta, \zeta) = \frac{1}{8}(1+\xi)(1-\eta)(1+\zeta)$$

$$N_3(\xi, \eta, \zeta) = \frac{1}{8}(1+\xi)(1+\eta)(1-\zeta) \quad N_7(\xi, \eta, \zeta) = \frac{1}{8}(1+\xi)(1+\eta)(1+\zeta)$$

$$N_4(\xi, \eta, \zeta) = \frac{1}{8}(1-\xi)(1+\eta)(1-\zeta) \quad N_8(\xi, \eta, \zeta) = \frac{1}{8}(1-\xi)(1+\eta)(1+\zeta)$$

$$x = \sum_{i=1}^8 N_i(\xi, \eta, \zeta) \cdot x_i, \quad T = \sum_{i=1}^8 N_i(\xi, \eta, \zeta) \cdot T_i$$

$$y = \sum_{i=1}^8 N_i(\xi, \eta, \zeta) \cdot y_i$$

$$z = \sum_{i=1}^8 N_i(\xi, \eta, \zeta) \cdot z_i$$

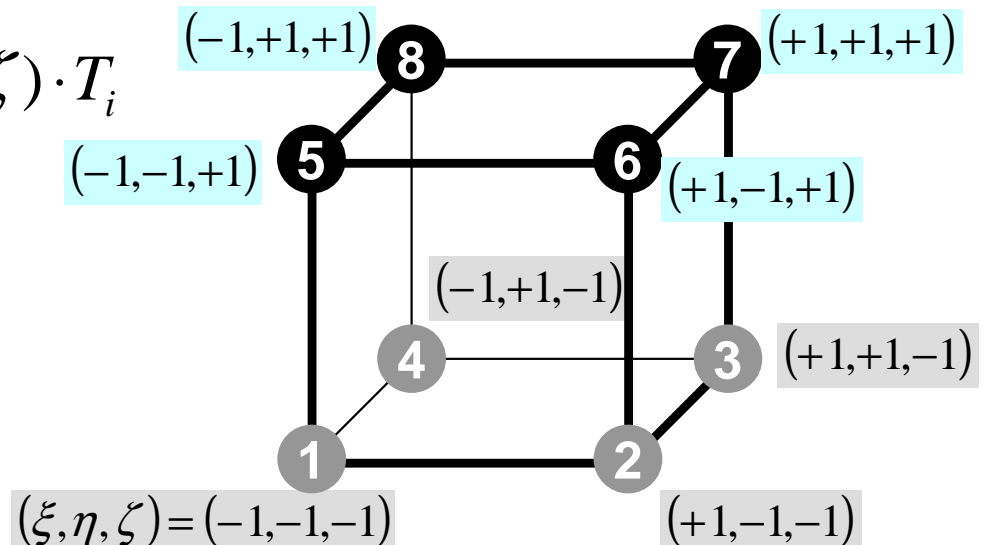

- Formulation of 3D Element
- **3D Heat Equations**
 - **Galerkin Method**
 - **Element Matrices**
- Running the Code
- Data Structure
- Overview of the Program

Galerkin Method (1/3)

- Governing Equation for 3D Steady State Heat Conduction Problems (uniform λ):

$$\left(\lambda \frac{\partial^2 T}{\partial x^2} \right) + \left(\lambda \frac{\partial^2 T}{\partial y^2} \right) + \left(\lambda \frac{\partial^2 T}{\partial z^2} \right) + \dot{Q} = 0$$

$$T = [N]\{\phi\} \quad \text{Distribution of temperature in each element (matrix form), } \phi: \text{ Temperature at each node}$$

- Following integral equation is obtained at each element by Galerkin method, where $[N]$'s are also weighting functions:

$$\int_V [N]^T \left\{ \lambda \left(\frac{\partial^2 T}{\partial x^2} \right) + \lambda \left(\frac{\partial^2 T}{\partial y^2} \right) + \lambda \left(\frac{\partial^2 T}{\partial z^2} \right) + \dot{Q} \right\} dV = 0$$

Galerkin Method (2/3)

- Green's Theorem (3D)

$$\int_V A \left(\frac{\partial^2 B}{\partial x^2} + \frac{\partial^2 B}{\partial y^2} + \frac{\partial^2 B}{\partial z^2} \right) dV = \int_S A \frac{\partial B}{\partial n} dS - \int_V \left(\frac{\partial A}{\partial x} \frac{\partial B}{\partial x} + \frac{\partial A}{\partial y} \frac{\partial B}{\partial y} + \frac{\partial A}{\partial z} \frac{\partial B}{\partial z} \right) dV$$

- Apply this to the 1st 3-parts of the equation with 2nd-order diff. (surface integration terms are ignored):

$$\begin{aligned} & \int_V [N]^T \{ \lambda(T_{,xx}) + \lambda(T_{,yy}) + \lambda(T_{,zz}) \} dV \\ &= - \int_V \{ \lambda([N_{,x}]^T T_{,x}) + \lambda([N_{,y}]^T T_{,y}) + \lambda([N_{,z}]^T T_{,z}) \} dV \end{aligned}$$

- Consider the following terms:

$$T = [N]\{\phi\}, \quad T_{,x} = [N_{,x}]\{\phi\}, \quad T_{,y} = [N_{,y}]\{\phi\}, \quad T_{,z} = [N_{,z}]\{\phi\}$$

Galerkin Method (3/3)

- Finally, following equation is obtained by considering heat generation term \dot{Q} :

$$-\int_V \left\{ \lambda \left([N_{,x}]^T [N_{,x}] \right) + \lambda \left([N_{,y}]^T [N_{,y}] \right) + \lambda \left([N_{,z}]^T [N_{,z}] \right) \right\} dV \cdot \{\phi\} + \int_V \dot{Q} [N] dV = 0$$

- This is called “weak form (弱形式)”. Original PDE consists of terms with 2nd-order diff., but this “weak form” only includes 1st-order diff by Green’s theorem.
 - Requirements for shape functions are “weaker” in “weak form”. Linear functions can describe effects of 2nd-order differentiation.
 - Same as 1D problem

Weak Form with B.C.: on each elem.

$$[k]^{(e)} \{\phi\}^{(e)} = \{f\}^{(e)}$$

$$[k]^{(e)} = \int_V \lambda ([N_{,x}]^T [N_{,x}]) dV + \int_V \lambda ([N_{,y}]^T [N_{,y}]) dV \\ + \int_V \lambda ([N_{,z}]^T [N_{,z}]) dV$$

$$\{f\}^{(e)} = \int_V \dot{Q} [N]^T dV$$

Element Matrix: 8x8

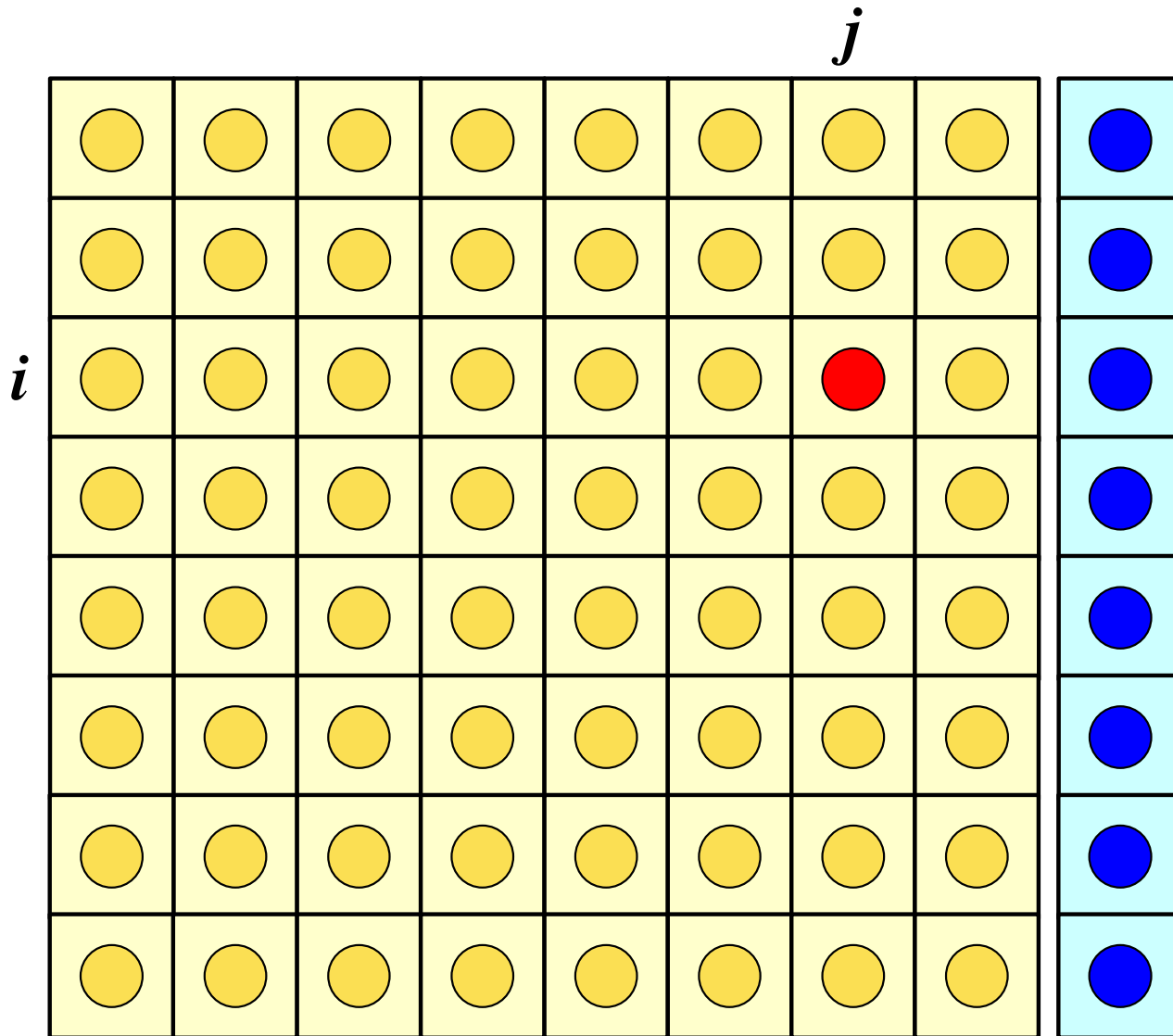

$$[k_{ij}] \quad (i, j = 1 \dots 8)$$

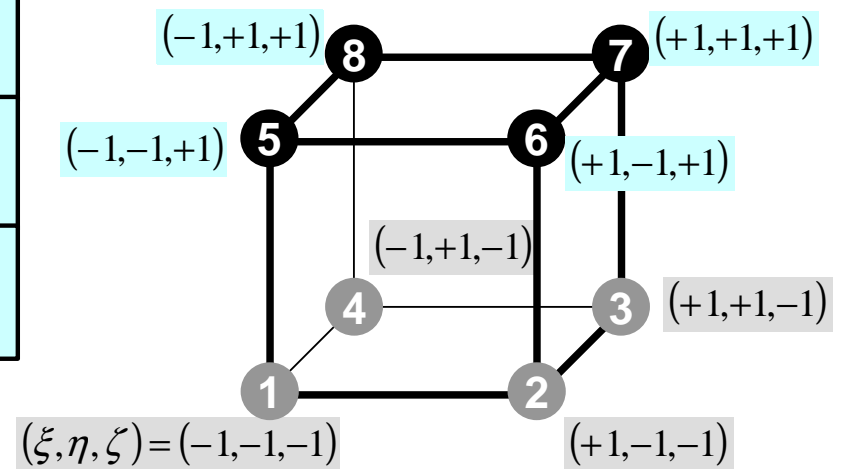

Element Matrix: k_{ij}

$$[k_{ij}] \quad (i, j = 1 \dots 8)$$

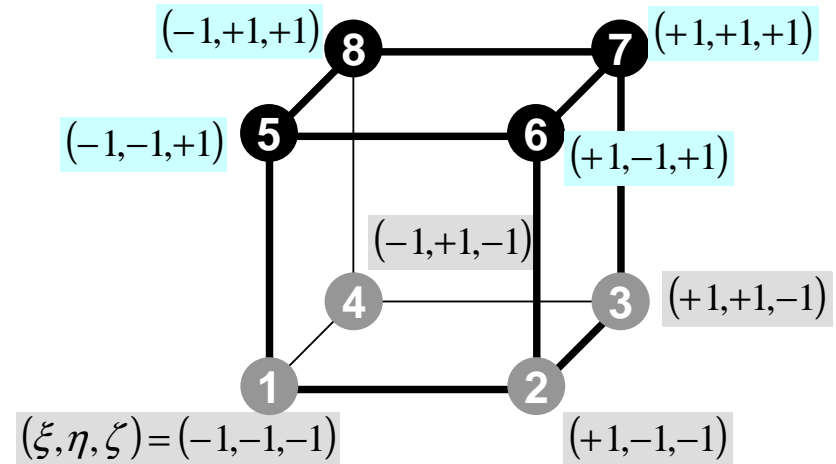

$$[k]^{(e)} = \int_V \lambda ([N_{,x}]^T [N_{,x}]) dV + \int_V \lambda ([N_{,y}]^T [N_{,y}]) dV + \int_V \lambda ([N_{,z}]^T [N_{,z}]) dV$$



$$k_{ij} = - \int_V \{ \lambda \cdot N_{i,x} \cdot N_{j,x} \} dV$$

$$k_{ij} = - \int_V \{ \lambda \cdot N_{i,x} \cdot N_{j,x} + \lambda \cdot N_{i,y} \cdot N_{j,y} + \lambda \cdot N_{i,z} \cdot N_{j,z} \} dV$$

Methods for Numerical Integration

- Trapezoidal Rule
- Simpson's Rule
- Gaussian Quadrature (or Gauss-Legendre)
 - accurate

- Values of functions at finite numbers of sample points are utilized:

$$\int_{X_1}^{X_2} f(x) dx \Rightarrow \sum_{k=1}^m [w_k \cdot f(x_k)]$$

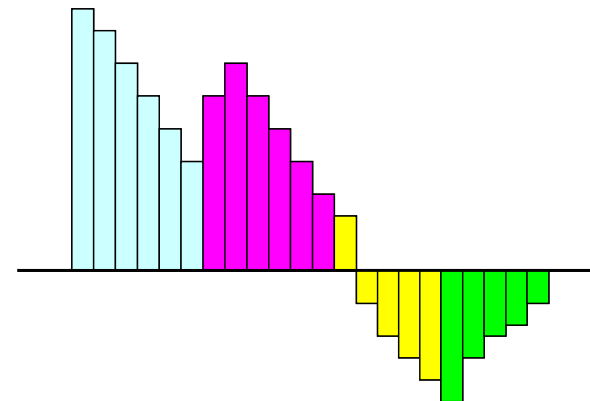

Gaussian Quadrature in 1D

more accurate than Simpson's rule

Simpson's

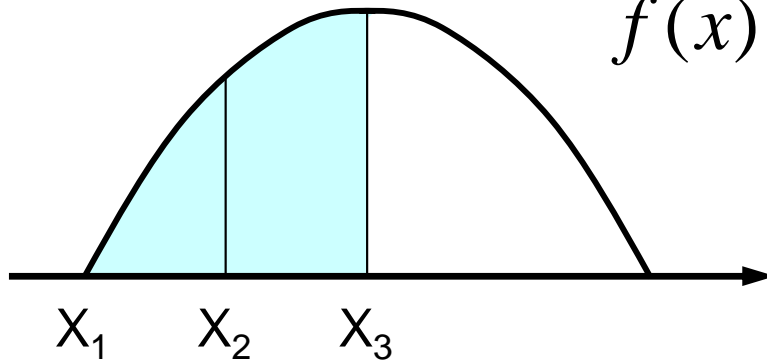

$$X_1 = 0, \quad X_2 = \frac{\pi}{4}, \quad X_3 = \frac{\pi}{2}$$

$$h = X_2 - X_1 = X_3 - X_1 = \frac{\pi}{4}$$

$$S = \frac{h}{3} [f(X_1) + 4f(X_2) + f(X_3)] = 1.0023$$

Gauss

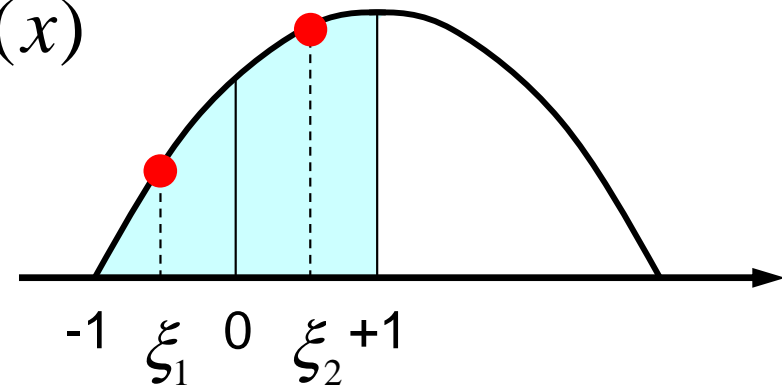

$$\xi_1, \xi_2 = \pm 0.5773502692$$

$$S = \int_0^{\pi/2} f(x) dx = \int_{-1}^{+1} f(\xi) h d\xi$$

$$\cong h \sum_{k=1}^2 W_k \cdot f(\xi_k) = 0.99847$$

Gaussian Quadrature

ガウスの積分公式

- On normalized “natural (or local)” coordinate system $[-1,+1]$ (自然座標系, 局所座標系)
- Can approximate up to $(2m-1)$ -th order of functions by m quadrature points ($m=2$ is enough for quadratic shape functions).

$$\int_{-1}^{+1} f(\xi) d\xi = \sum_{k=1}^m [w_k \cdot f(\xi_k)]$$

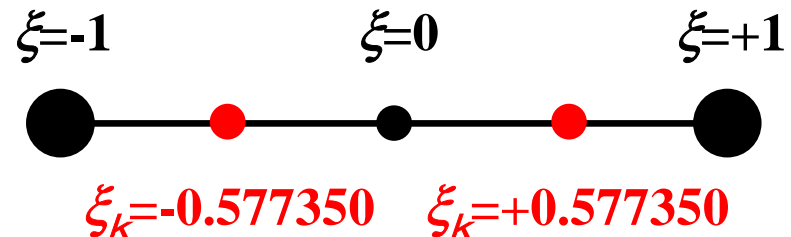

$$m = 1 \quad \xi_k = 0.00, w_k = 2.00$$

$$m = 2 \quad \xi_k = \pm 0.577350, w_k = 1.00$$

$$m = 3 \quad \xi_k = 0.00, w_k = 8/9$$

$$\xi_k = \pm 0.774597, w_k = 5/9$$

Gaussian Quadrature

can be easily extended to 2D & 3D

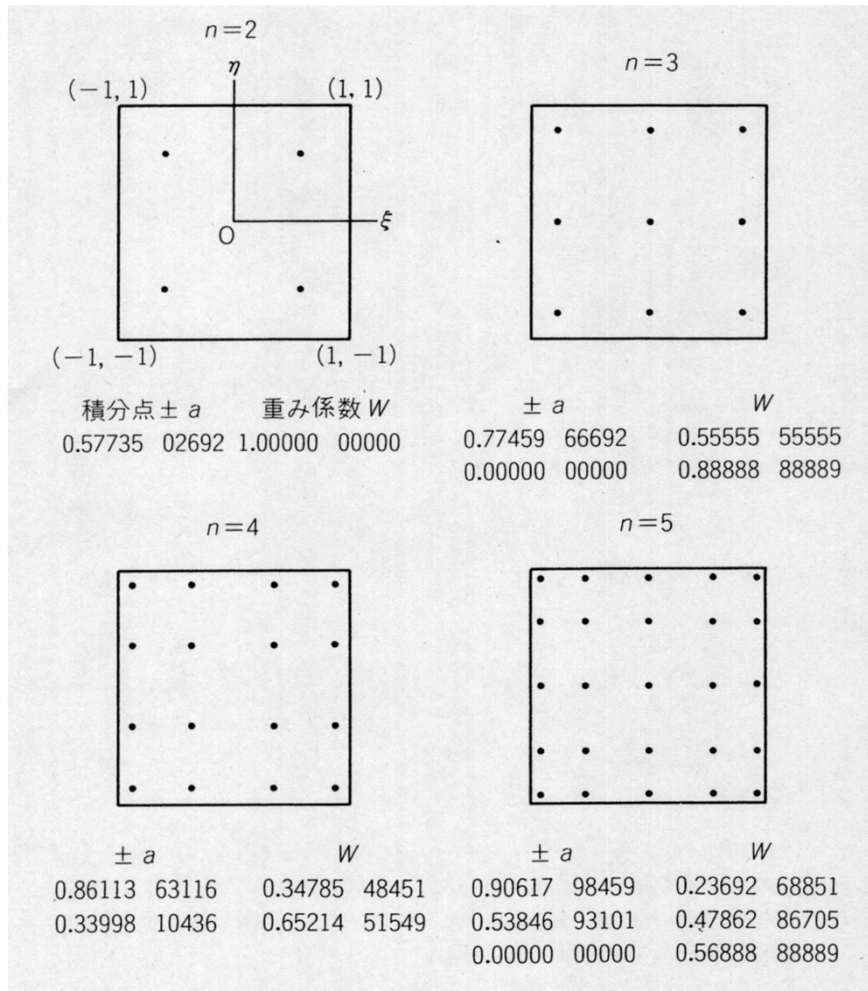

$$I = \int_{-1}^{+1} \int_{-1}^{+1} f(\xi, \eta) d\xi d\eta$$

$$= \sum_{i=1}^m \sum_{j=1}^n [W_i \cdot W_j \cdot f(\xi_i, \eta_j)]$$

m, n : number of quadrature points in ξ, η -direction

(ξ_i, η_j) : Coordinates of Quad's

W_i, W_j : Weighting Factor

Gaussian Quadrature

ガウスの積分公式

This configuration is widely used. In 2D problem, integration is done using values of “f” at 4 quad. points.

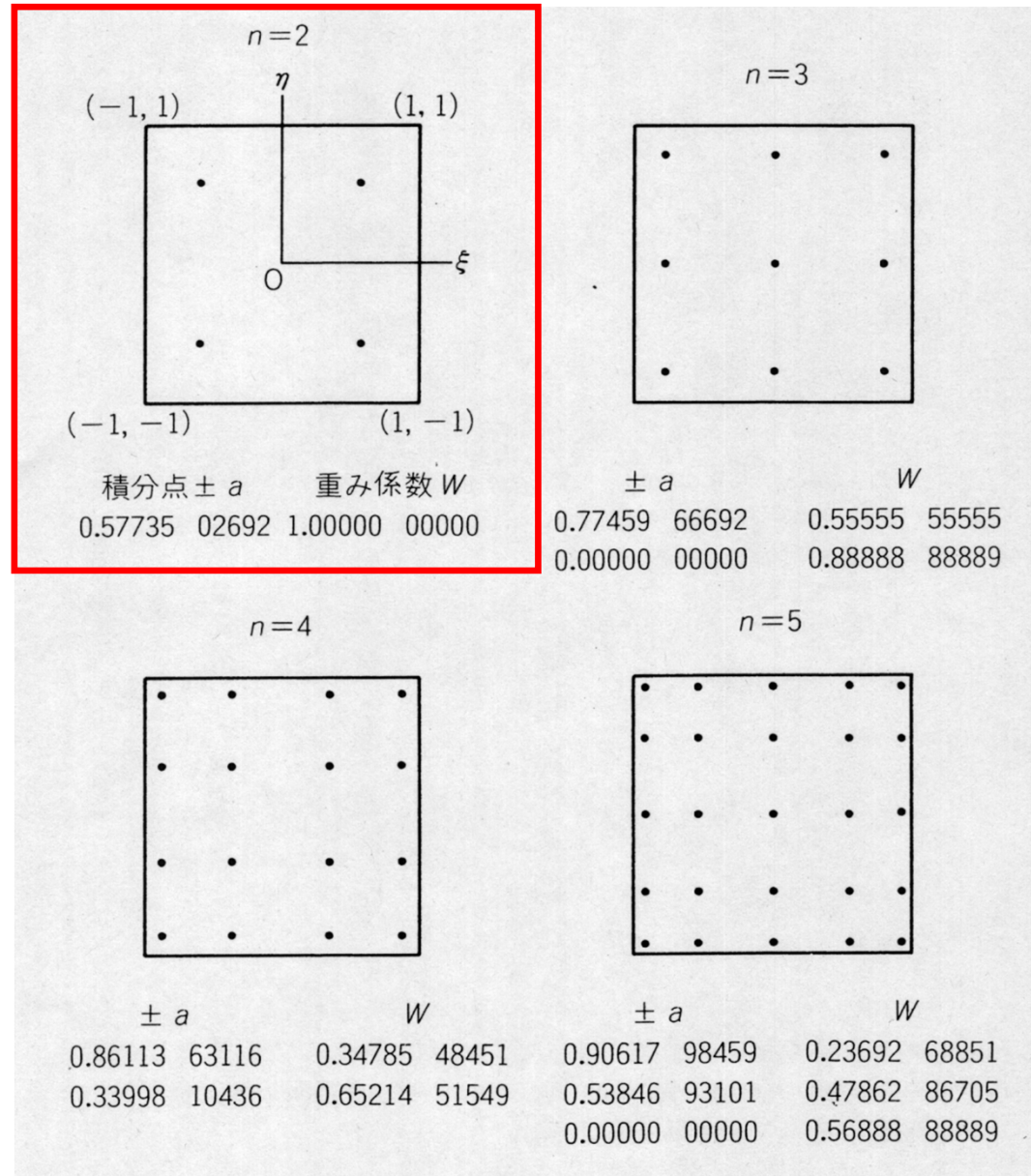

Gaussian Quadrature

ガウスの積分公式

This configuration is widely used. In 2D problem, integration is done using values of “f” at 4 quad. points.

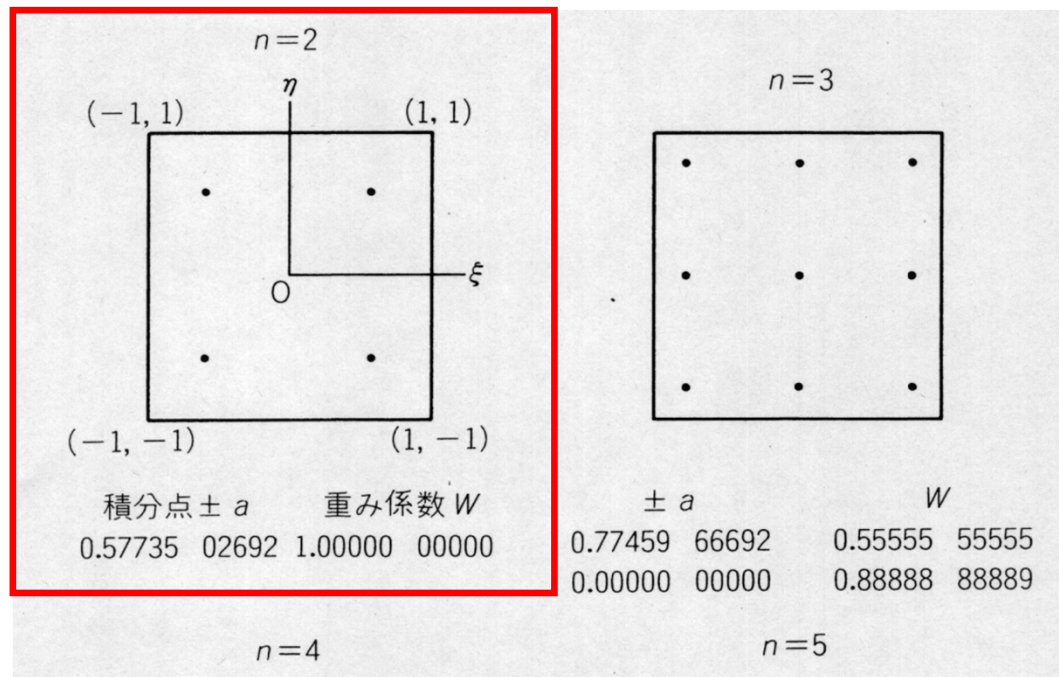

$$I = \int_{-1}^{+1} \int_{-1}^{+1} f(\xi, \eta) d\xi d\eta = \sum_{i=1}^m \sum_{j=1}^n [w_i \cdot w_j \cdot f(\xi_i, \eta_j)]$$

$$= 1.0 \times 1.0 \times f(-0.57735, -0.57735) + 1.0 \times 1.0 \times f(-0.57735, +0.57735) \\ + 1.0 \times 1.0 \times f(+0.57735, +0.57735) + 1.0 \times 1.0 \times f(+0.57735, -0.57735)$$

0.33998	0.10436	0.05214	0.51549	0.33846	0.95101	0.47802	0.0705
0.00000	0.00000	0.56888	0.88889	0.00000	0.00000	0.56888	0.88889

Next Stage: Integration

- 3D Natural/Local Coordinate (ξ, η, ζ) :
 - Gaussian Quadrature

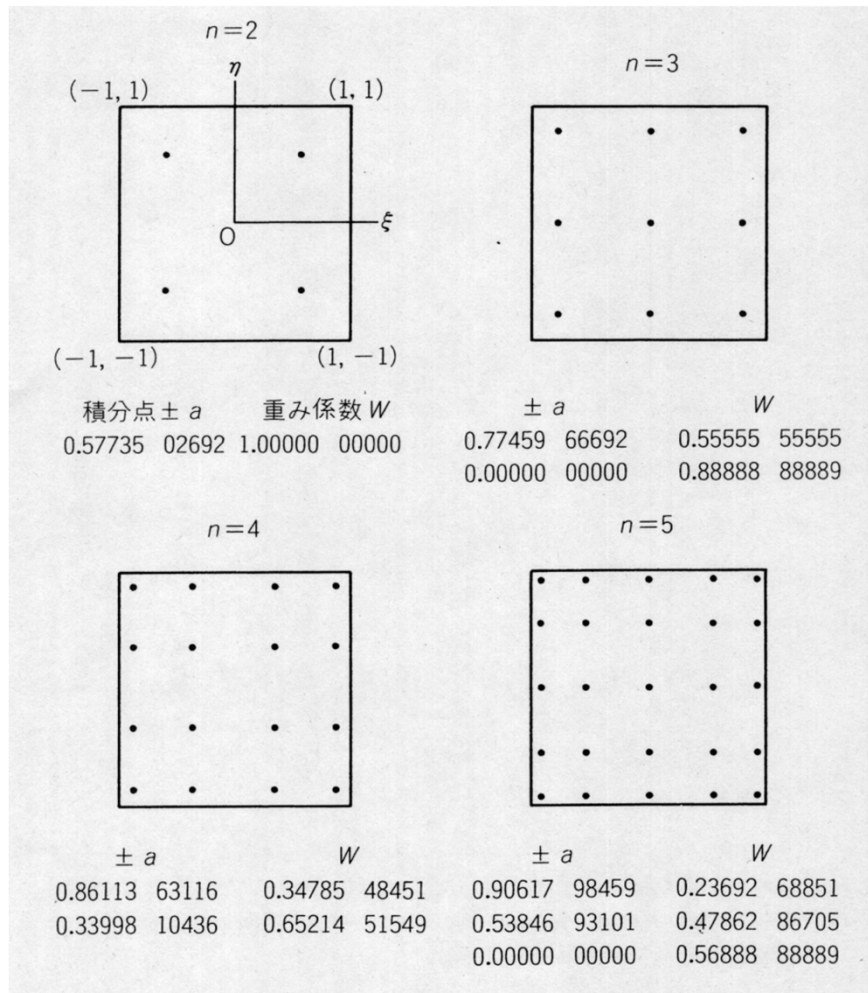

$$I = \int_{-1}^{+1} \int_{-1}^{+1} \int_{-1}^{+1} f(\xi, \eta, \zeta) d\xi d\eta d\zeta$$

$$= \sum_{i=1}^L \sum_{j=1}^M \sum_{k=1}^N [W_i \cdot W_j \cdot W_k \cdot f(\xi_i, \eta_j, \zeta_k)]$$

L, M, N : number of quadrature points in ξ, η, ζ -direction

(ξ_i, η_j, ζ_k) : Coordinates of Quad's

W_i, W_j, W_k : Weighting Factor

Partial Diff. on Natural Coord. (1/4)

- According to formulae:

$$\frac{\partial N_i(\xi, \eta, \zeta)}{\partial \xi} = \frac{\partial N_i}{\partial x} \frac{\partial x}{\partial \xi} + \frac{\partial N_i}{\partial y} \frac{\partial y}{\partial \xi} + \frac{\partial N_i}{\partial z} \frac{\partial z}{\partial \xi}$$

$$\frac{\partial N_i(\xi, \eta, \zeta)}{\partial \eta} = \frac{\partial N_i}{\partial x} \frac{\partial x}{\partial \eta} + \frac{\partial N_i}{\partial y} \frac{\partial y}{\partial \eta} + \frac{\partial N_i}{\partial z} \frac{\partial z}{\partial \eta}$$

$$\frac{\partial N_i(\xi, \eta, \zeta)}{\partial \zeta} = \frac{\partial N_i}{\partial x} \frac{\partial x}{\partial \zeta} + \frac{\partial N_i}{\partial y} \frac{\partial y}{\partial \zeta} + \frac{\partial N_i}{\partial z} \frac{\partial z}{\partial \zeta}$$

$\left[\frac{\partial N_i}{\partial \xi}, \frac{\partial N_i}{\partial \eta}, \frac{\partial N_i}{\partial \zeta} \right]$ can be easily derived according to definitions.

$\left[\frac{\partial N_i}{\partial x}, \frac{\partial N_i}{\partial y}, \frac{\partial N_i}{\partial z} \right]$ are required for computations.

Partial Diff. on Natural Coord. (2/4)

- In matrix form:

$$\begin{Bmatrix} \frac{\partial N_i}{\partial \xi} \\ \frac{\partial N_i}{\partial \eta} \\ \frac{\partial N_i}{\partial \zeta} \end{Bmatrix} = \begin{bmatrix} \frac{\partial x}{\partial \xi} & \frac{\partial y}{\partial \xi} & \frac{\partial z}{\partial \xi} \\ \frac{\partial x}{\partial \eta} & \frac{\partial y}{\partial \eta} & \frac{\partial z}{\partial \eta} \\ \frac{\partial x}{\partial \zeta} & \frac{\partial y}{\partial \zeta} & \frac{\partial z}{\partial \zeta} \end{bmatrix} \begin{Bmatrix} \frac{\partial N_i}{\partial x} \\ \frac{\partial N_i}{\partial y} \\ \frac{\partial N_i}{\partial z} \end{Bmatrix} = [J] \begin{Bmatrix} \frac{\partial N_i}{\partial x} \\ \frac{\partial N_i}{\partial y} \\ \frac{\partial N_i}{\partial z} \end{Bmatrix}$$

$[J]$: Jacobi matrix, Jacobian

Partial Diff. on Natural Coord. (3/4)

- Components of Jacobian:

$$J_{11} = \frac{\partial x}{\partial \xi} = \frac{\partial}{\partial \xi} \left(\sum_{i=1}^8 N_i x_i \right) = \sum_{i=1}^8 \frac{\partial N_i}{\partial \xi} x_i, \quad J_{12} = \frac{\partial y}{\partial \xi} = \frac{\partial}{\partial \xi} \left(\sum_{i=1}^8 N_i y_i \right) = \sum_{i=1}^8 \frac{\partial N_i}{\partial \xi} y_i,$$

$$J_{13} = \frac{\partial z}{\partial \xi} = \frac{\partial}{\partial \xi} \left(\sum_{i=1}^8 N_i z_i \right) = \sum_{i=1}^8 \frac{\partial N_i}{\partial \xi} z_i$$

$$J_{21} = \frac{\partial x}{\partial \eta} = \frac{\partial}{\partial \eta} \left(\sum_{i=1}^8 N_i x_i \right) = \sum_{i=1}^8 \frac{\partial N_i}{\partial \eta} x_i, \quad J_{22} = \frac{\partial y}{\partial \eta} = \frac{\partial}{\partial \eta} \left(\sum_{i=1}^8 N_i y_i \right) = \sum_{i=1}^8 \frac{\partial N_i}{\partial \eta} y_i,$$

$$J_{23} = \frac{\partial z}{\partial \eta} = \frac{\partial}{\partial \eta} \left(\sum_{i=1}^8 N_i z_i \right) = \sum_{i=1}^8 \frac{\partial N_i}{\partial \eta} z_i$$

$$J_{31} = \frac{\partial x}{\partial \zeta} = \frac{\partial}{\partial \zeta} \left(\sum_{i=1}^8 N_i x_i \right) = \sum_{i=1}^8 \frac{\partial N_i}{\partial \zeta} x_i, \quad J_{32} = \frac{\partial y}{\partial \zeta} = \frac{\partial}{\partial \zeta} \left(\sum_{i=1}^8 N_i y_i \right) = \sum_{i=1}^8 \frac{\partial N_i}{\partial \zeta} y_i,$$

$$J_{33} = \frac{\partial z}{\partial \zeta} = \frac{\partial}{\partial \zeta} \left(\sum_{i=1}^8 N_i z_i \right) = \sum_{i=1}^8 \frac{\partial N_i}{\partial \zeta} z_i$$

Partial Diff. on Natural Coord. (4/4)

- Partial differentiation on global coordinate system is introduced as follows (with inverse of Jacobian matrix (3×3))

$$\begin{Bmatrix} \frac{\partial N_i}{\partial x} \\ \frac{\partial N_i}{\partial y} \\ \frac{\partial N_i}{\partial z} \end{Bmatrix} = \begin{bmatrix} \frac{\partial x}{\partial \xi} & \frac{\partial y}{\partial \xi} & \frac{\partial z}{\partial \xi} \\ \frac{\partial x}{\partial \eta} & \frac{\partial y}{\partial \eta} & \frac{\partial z}{\partial \eta} \\ \frac{\partial x}{\partial \zeta} & \frac{\partial y}{\partial \zeta} & \frac{\partial z}{\partial \zeta} \end{bmatrix}^{-1} \begin{Bmatrix} \frac{\partial N_i}{\partial \xi} \\ \frac{\partial N_i}{\partial \eta} \\ \frac{\partial N_i}{\partial \zeta} \end{Bmatrix} = [J]^{-1} \begin{Bmatrix} \frac{\partial N_i}{\partial \xi} \\ \frac{\partial N_i}{\partial \eta} \\ \frac{\partial N_i}{\partial \zeta} \end{Bmatrix}$$

Integration on Element

$$[k_{ij}] \quad (i, j = 1 \dots 8)$$

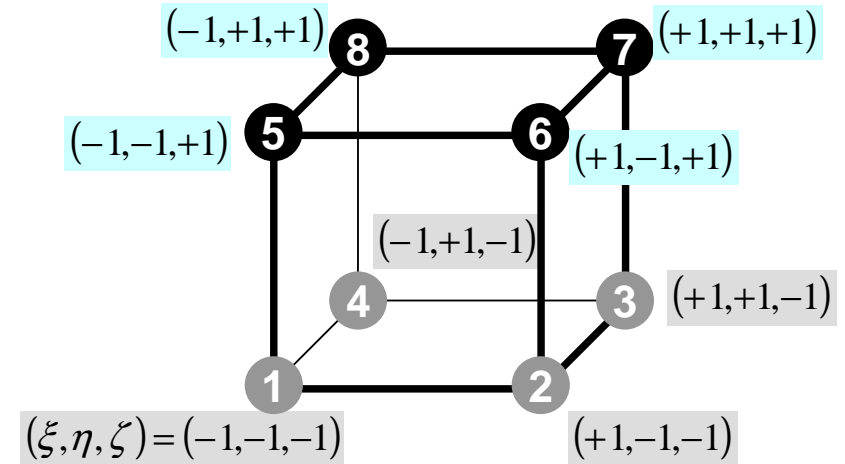

$$k_{ij} = - \int_V \left\{ \lambda \cdot N_{i,x} \cdot N_{j,x} + \lambda \cdot N_{i,y} \cdot N_{j,y} + \lambda \cdot N_{i,z} \cdot N_{j,z} \right\} dV$$

$$= - \int_V \left\{ \lambda \frac{\partial N_i}{\partial x} \frac{\partial N_j}{\partial x} + \lambda \frac{\partial N_i}{\partial y} \frac{\partial N_j}{\partial y} + \lambda \frac{\partial N_i}{\partial z} \frac{\partial N_j}{\partial z} \right\} dV$$

Integration on Natural Coord.

$$[k_{ij}] \quad (i, j = 1 \dots 8)$$

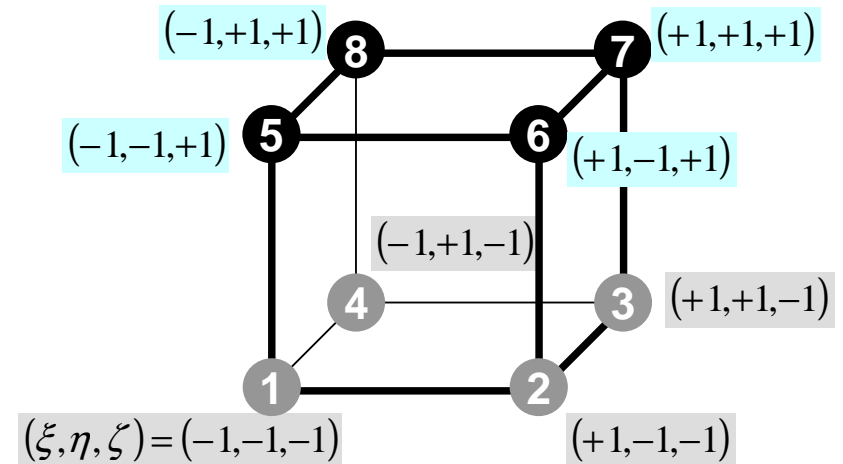

$$-\int_V \left\{ \lambda \frac{\partial N_i}{\partial x} \frac{\partial N_j}{\partial x} + \lambda \frac{\partial N_i}{\partial y} \frac{\partial N_j}{\partial y} + \lambda \frac{\partial N_i}{\partial z} \frac{\partial N_j}{\partial z} \right\} dV =$$

$$-\iiint \left\{ \lambda \frac{\partial N_i}{\partial x} \frac{\partial N_j}{\partial x} + \lambda \frac{\partial N_i}{\partial y} \frac{\partial N_j}{\partial y} + \lambda \frac{\partial N_i}{\partial z} \frac{\partial N_j}{\partial z} \right\} dx dy dz =$$

$$-\int_{-1}^{+1} \int_{-1}^{+1} \int_{-1}^{+1} \left\{ \lambda \frac{\partial N_i}{\partial x} \frac{\partial N_j}{\partial x} + \lambda \frac{\partial N_i}{\partial y} \frac{\partial N_j}{\partial y} + \lambda \frac{\partial N_i}{\partial z} \frac{\partial N_j}{\partial z} \right\} \det|J| d\xi d\eta d\zeta$$

Gaussian Quadrature

$$[k_{ij}] \quad (i, j = 1 \dots 8)$$

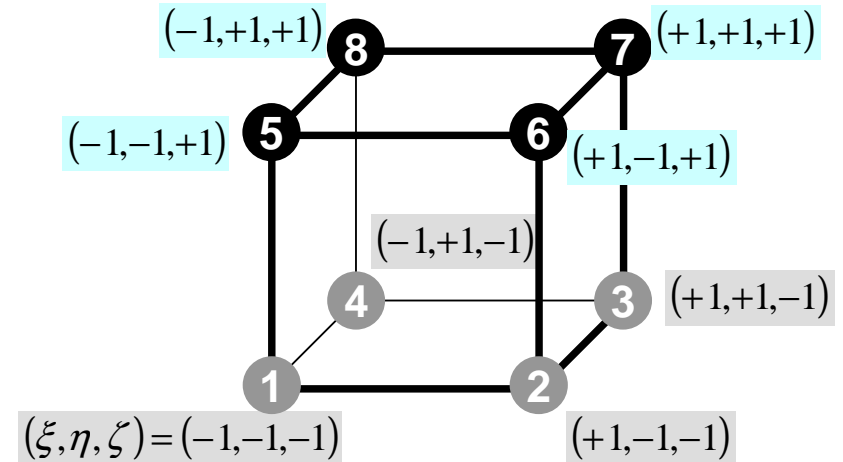

$$- \int_{-1}^{+1} \int_{-1}^{+1} \int_{-1}^{+1} \left\{ \lambda \frac{\partial N_i}{\partial x} \frac{\partial N_j}{\partial x} + \lambda \frac{\partial N_i}{\partial y} \frac{\partial N_j}{\partial y} + \lambda \frac{\partial N_i}{\partial z} \frac{\partial N_j}{\partial z} \right\} \det |J| d\xi d\eta d\zeta$$

$$I = \int_{-1}^{+1} \int_{-1}^{+1} \int_{-1}^{+1} f(\xi, \eta, \zeta) d\xi d\eta d\zeta$$

$$= \sum_{i=1}^L \sum_{j=1}^M \sum_{k=1}^N [w_i \cdot w_j \cdot w_k \cdot f(\xi_i, \eta_j, \zeta_k)]$$

Remaining Procedures

- Element matrices have been formed.
- Accumulation to Global Matrix
- Implementation of Boundary Conditions
- Solving Linear Equations
- Details of implementation will be discussed in classes later than next week through explanation of programs

Accumulation: Local -> Global Matrices

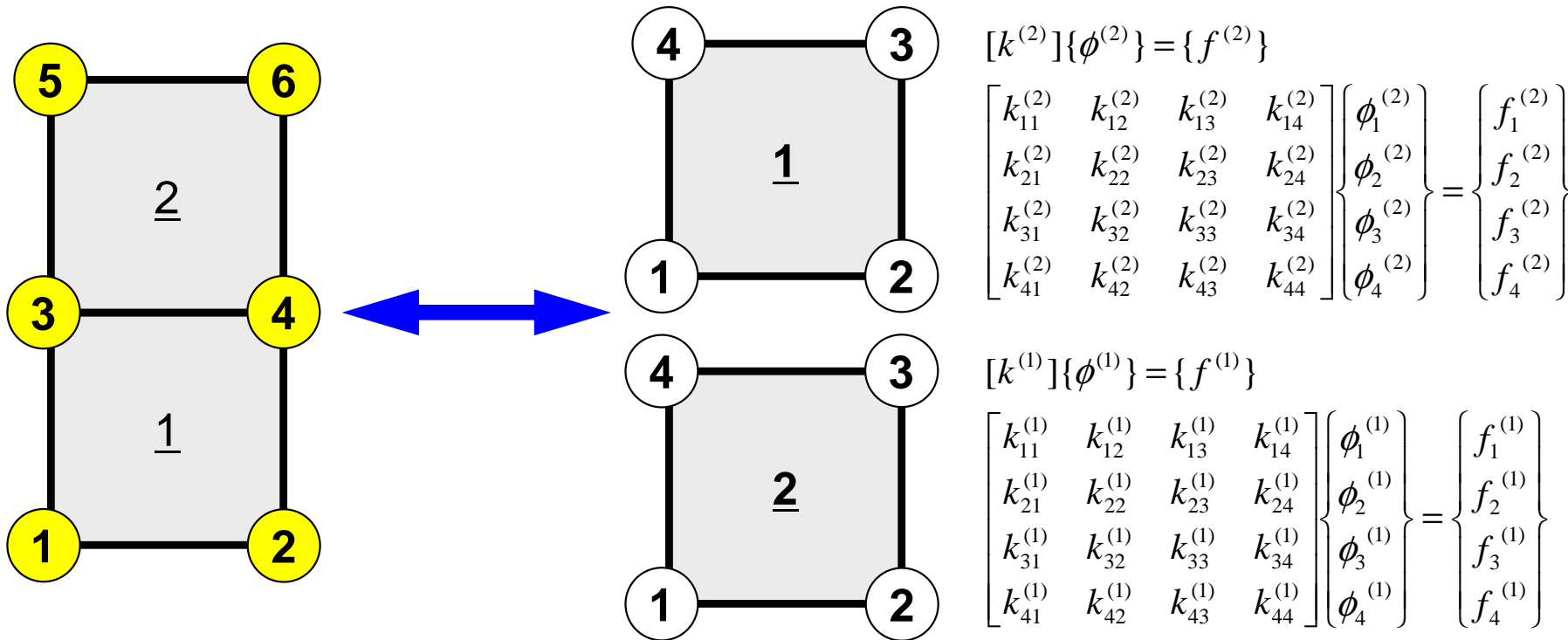

$$[K]\{\Phi\} = \{F\}$$

$$\begin{bmatrix} D_1 & X & X & X & & & \\ X & D_2 & X & X & & & \\ X & X & D_3 & X & X & X & \\ X & X & X & D_4 & X & X & \\ & & X & X & D_5 & X & \\ & & X & X & X & D_6 & \end{bmatrix} \begin{Bmatrix} \Phi_1 \\ \Phi_2 \\ \Phi_3 \\ \Phi_4 \\ \Phi_5 \\ \Phi_6 \end{Bmatrix} = \begin{Bmatrix} B_1 \\ B_2 \\ B_3 \\ B_4 \\ B_5 \\ B_6 \end{Bmatrix}$$

- Formulation of 3D Element
- 3D Heat Equations
 - Galerkin Method
 - Element Matrices
 - **Exercise**
- Running the Code
- Data Structure
- Overview of the Program

Exercise

- Develop a program and calculate area of the following quadrilateral using Gaussian Quadrature.

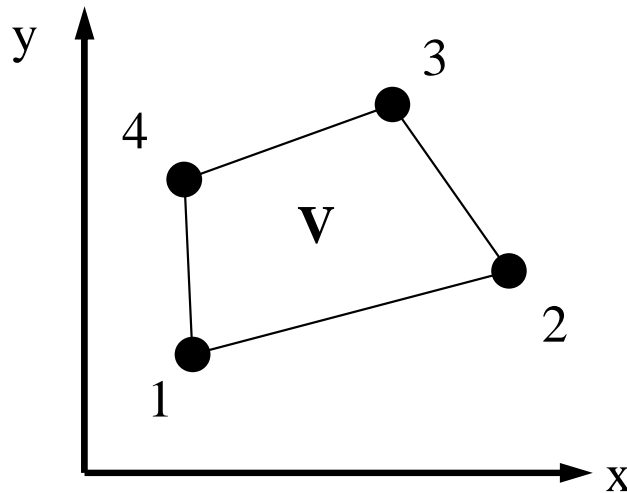

1: (1.0, 1.0)
2: (4.0, 2.0)
3: (3.0, 5.0)
4: (2.0, 4.0)

$$I = \int_V dV = \int_{-1}^{+1} \int_{-1}^{+1} \det|J| d\xi d\zeta$$

Tips (1/2)

- Calculate Jacobian
- Apply Gaussian Quadrature (n=2)

$$I = \int_{-1}^{+1} \int_{-1}^{+1} f(\xi, \eta) d\xi d\eta = \sum_{i=1}^m \sum_{j=1}^n [W_i \cdot W_j \cdot f(\xi_i, \eta_j)]$$

```

implicit REAL*8 (A-H,O-Z)
real*8 W(2)
real*8 POI(2)

W(1)= 1.0d0
W(2)= 1.0d0
POI(1)= -0.5773502692d0
POI(2)= +0.5773502692d0

SUM= 0.d0
do jp= 1, 2
do ip= 1, 2
    FC = F(POI(ip),POI(jp))
    SUM= SUM + W (ip)*W (jp)*FC
enddo
enddo

```

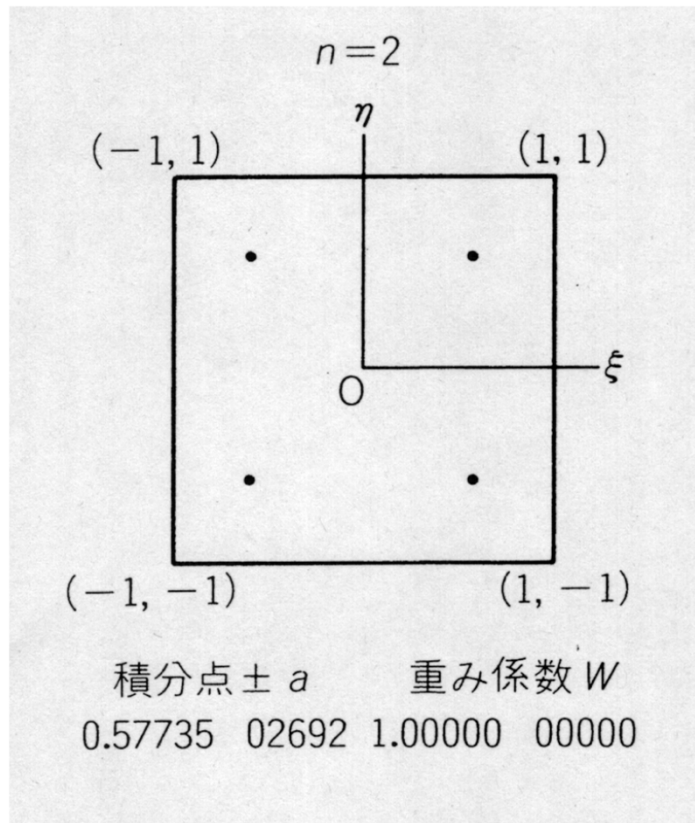

Tips (2/2)

$$[J] = \begin{bmatrix} \frac{\partial x}{\partial \xi} & \frac{\partial y}{\partial \xi} \\ \frac{\partial x}{\partial \eta} & \frac{\partial y}{\partial \eta} \end{bmatrix}, \quad \det|J| = \frac{\partial x}{\partial \xi} \cdot \frac{\partial y}{\partial \eta} - \frac{\partial y}{\partial \xi} \cdot \frac{\partial x}{\partial \eta}$$

$$\frac{\partial x}{\partial \xi} = \frac{\partial}{\partial \xi} \left(\sum_{i=1}^4 N_i x_i \right) = \sum_{i=1}^4 \frac{\partial N_i}{\partial \xi} x_i, \quad \frac{\partial y}{\partial \xi} = \frac{\partial}{\partial \xi} \left(\sum_{i=1}^4 N_i y_i \right) = \sum_{i=1}^4 \frac{\partial N_i}{\partial \xi} y_i,$$

$$\frac{\partial x}{\partial \eta} = \frac{\partial}{\partial \eta} \left(\sum_{i=1}^4 N_i x_i \right) = \sum_{i=1}^4 \frac{\partial N_i}{\partial \eta} x_i, \quad \frac{\partial y}{\partial \eta} = \frac{\partial}{\partial \eta} \left(\sum_{i=1}^4 N_i y_i \right) = \sum_{i=1}^4 \frac{\partial N_i}{\partial \eta} y_i$$

$$N_1(\xi, \eta) = \frac{1}{4} (1 - \xi)(1 - \eta), \quad N_2(\xi, \eta) = \frac{1}{4} (1 + \xi)(1 - \eta),$$

$$N_3(\xi, \eta) = \frac{1}{4} (1 + \xi)(1 + \eta), \quad N_4(\xi, \eta) = \frac{1}{4} (1 - \xi)(1 + \eta)$$

- Formulation of 3D Element
- 3D Heat Equations
 - Galerkin Method
 - Element Matrices
- **Running the Code**
- Data Structure
- Overview of the Program

3D Steady-State Heat Conduction

$$\frac{\partial}{\partial x} \left(\lambda \frac{\partial T}{\partial x} \right) + \frac{\partial}{\partial y} \left(\lambda \frac{\partial T}{\partial y} \right) + \frac{\partial}{\partial z} \left(\lambda \frac{\partial T}{\partial z} \right) + \dot{Q}(x, y, z) = 0$$

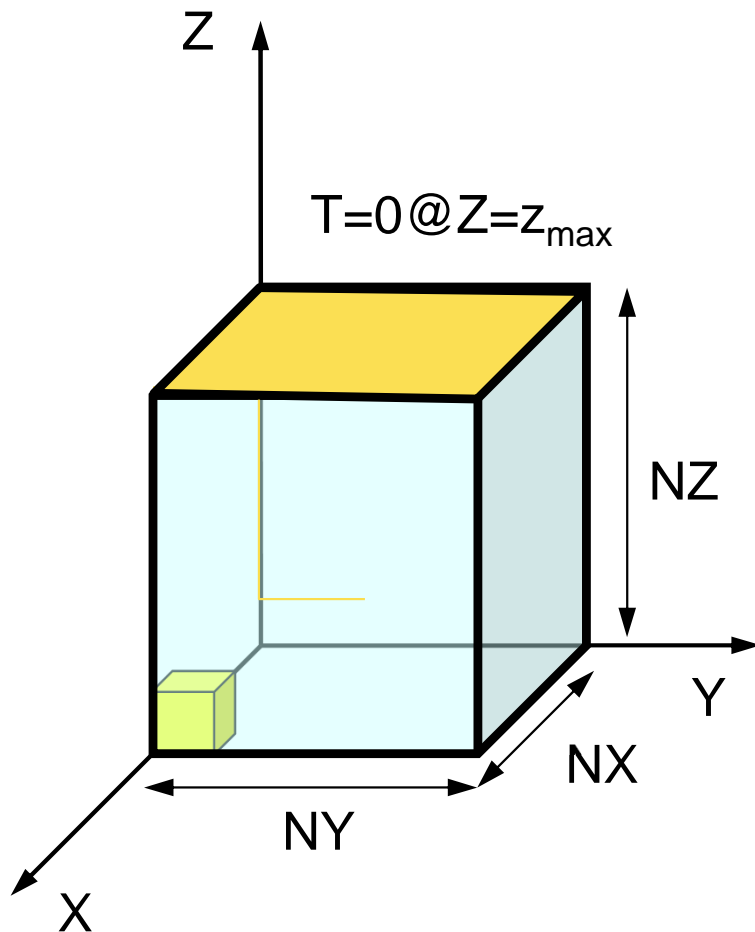

- Heat Generation
- Uniform thermal conductivity λ
- HEX meshes
 - 1x1x1 cubes
 - NX, NY, NZ cubes in each direction
- Boundary Conditions
 - $T=0@Z=Z_{\max}$
- Heat Gen. Rate is a function of location (cell center: x_c, y_c)
 - $\dot{Q}(x, y, z) = QVOL|x_c + y_c|$

Copy/Installation

Install

```
>$ cd
>$ cd fem-f/fem3d/src
>$ make
>$ ls ../run/sol
sol
```

Install of Mesh Generator

```
>$ cd
>$ cd fem-f/fem3d/run
>$ gfortran -O3 mgcube.f -o mgcube
```

Operations

Starting from Grid Generation to Computation, File-
names are fixed

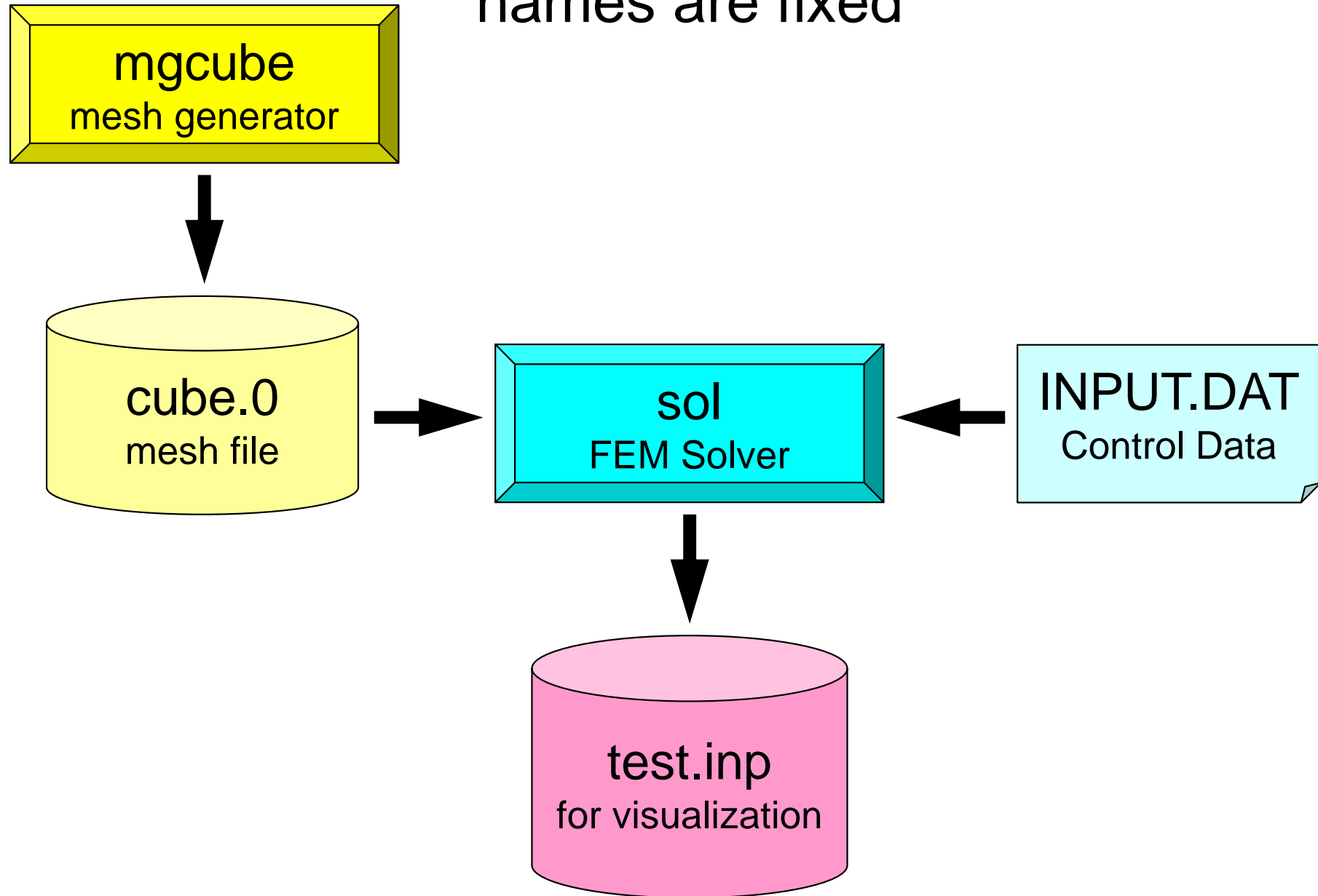

Mesh Generation

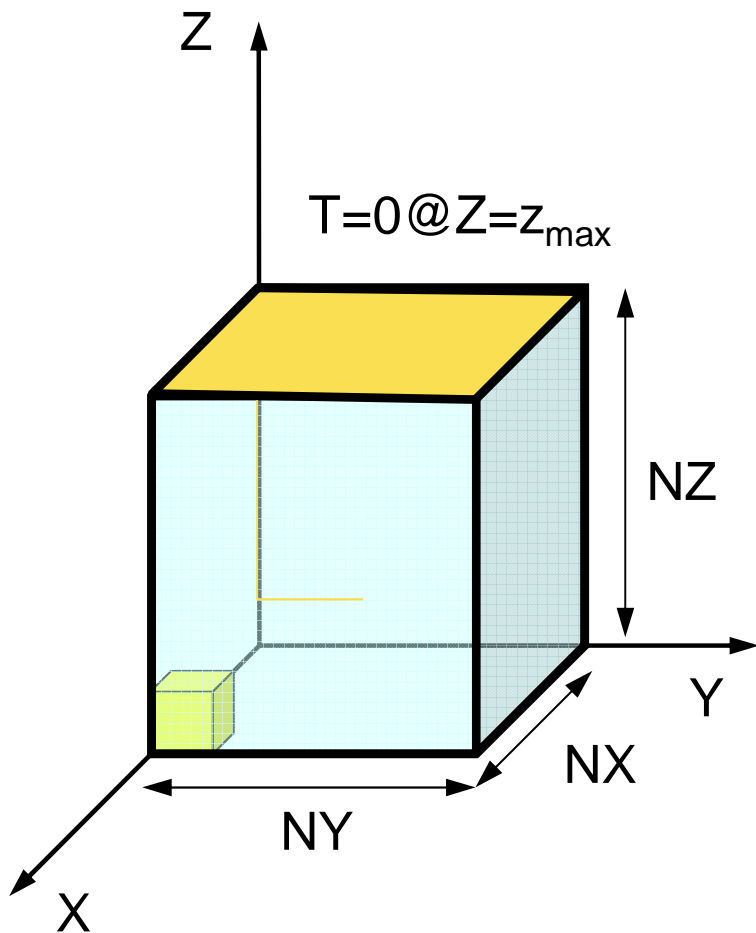

```
>$ cd  
>$ cd fem-f/fem3d/run  
>$ ./mgcube.exe (or ./mgcube)
```

`NX, NY, NZ` ← Number of
Elem's in each
direction

`20, 20, 20` ← example

```
>$ ls cube.0           confirmation  
cube.0
```

Control File: INPUT.DAT

INPUT.DAT

```

cube.0      fname
2000        ITER
1.0 1.0     COND, QVOL
1.0e-08     RESID

```

- `fname` : Name of Mesh File
- `ITER` : Max. Iterations for CG
- `COND` : Thermal Conductivity
- `QVOL` : Heat Generation Rate
- `RESID` : Criteria for Convergence of CG

$$\frac{\partial}{\partial x} \left(\lambda \frac{\partial T}{\partial x} \right) + \frac{\partial}{\partial y} \left(\lambda \frac{\partial T}{\partial y} \right) + \frac{\partial}{\partial z} \left(\lambda \frac{\partial T}{\partial z} \right) + \dot{Q}(x, y, z) = 0$$

$$\dot{Q}(x, y, z) = QVOL |x_c + y_c|$$

Running

```
>$ cd
>$ cd fem-c/fem3d/run
>$ ./sol.exe (or ./sol)
```

```
>$ ls test.inp          Confirmation
    test.inp
```

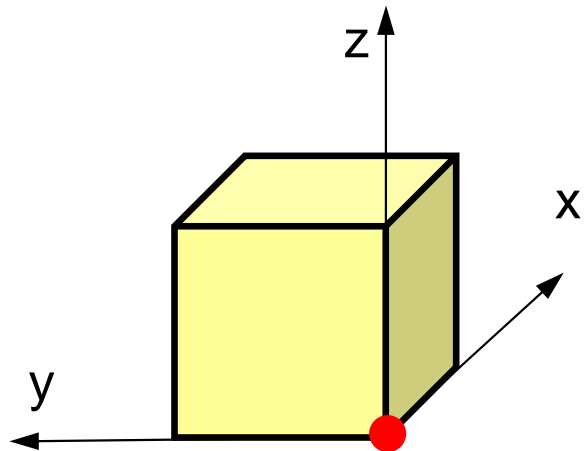

```
1 4.025833e+00
2 3.628020e+00
3 3.319234e+00
4 3.073771e+00
(...)
55 9.238550e-07
56 3.876258e-07
57 1.854812e-07
58 1.062119e-07
59 3.541404e-08
60 1.284087e-08
61 6.073277e-09

1 3.391200e+03
```

Total Number of Iterations

Temperature at Origin (0,0,0)

ParaView

- <http://www.paraview.org/>
- Opening files
- Displaying figures
- Saving image files
 - <http://nkl.cc.u-tokyo.ac.jp/20w/ParaView.pdf>

UCD Format (1/3)

Unstructured Cell Data

要素の種類

キーワード

点

pt

線

line

三角形

tri

四角形

quad

四面体

tet

角錐

pyr

三角柱

prism

六面体

hex

二次要素

線2

line2

三角形2

tri2

四角形2

quad2

四面体2

tet2

角錐2

pyr2

三角柱2

prism2

六面体2

hex2

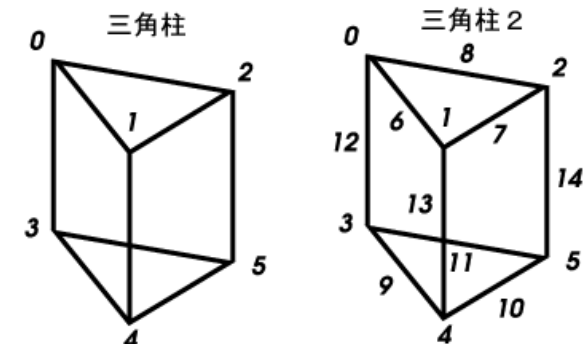
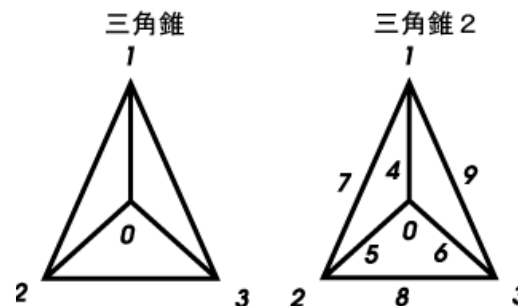
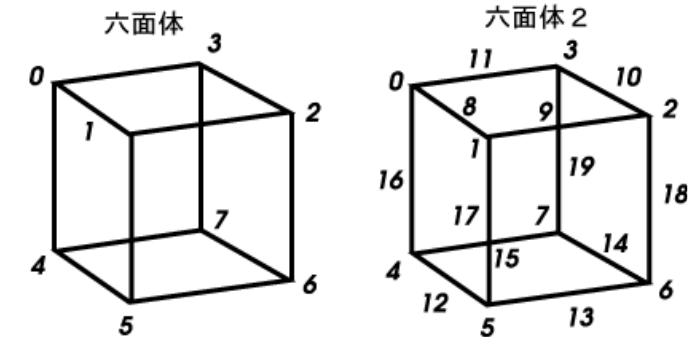
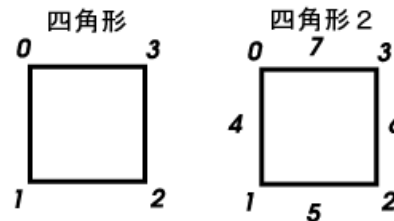
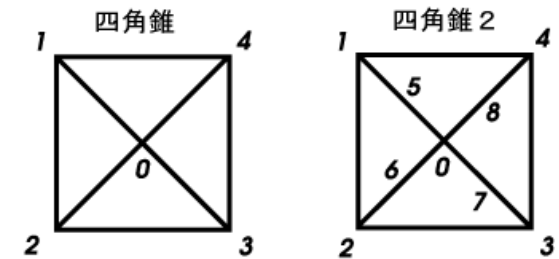
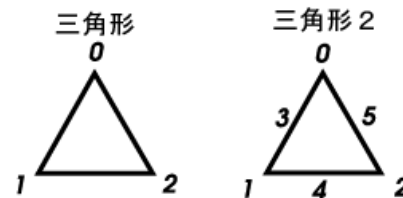
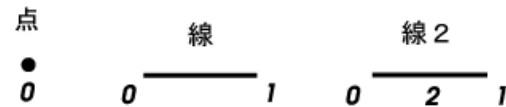

UCD Format (2/3)

- Originally for AVS, microAVS
- Extension of the UCD file is “inp”
- There are two types of formats. Only old type can be read by ParaView.

UCD Format (3/3): Old Format

(全節点数) (全要素数) (各節点のデータ数) (各要素のデータ数) (モデルのデータ数)

(節点番号1) (X座標) (Y座標) (Z座標)
(節点番号2) (X座標) (Y座標) (Z座標)

⋮

(要素番号1) (材料番号) (要素の種類) (要素を構成する節点のつながり)
(要素番号2) (材料番号) (要素の種類) (要素を構成する節点のつながり)

⋮

(節点のデータ成分数) (成分1の構成数) (成分2の構成数) ⋯ (各成分の構成数)
(節点データ成分1のラベル), (単位)
(節点データ成分2のラベル), (単位)

⋮

(各節点データ成分のラベル), (単位)
(節点番号1) (節点データ1) (節点データ2) ⋯
(節点番号2) (節点データ1) (節点データ2) ⋯

⋮

(要素のデータ成分数) (成分1の構成数) (成分2の構成数) ⋯ (各成分の構成数)
(要素データ成分1のラベル), (単位)
(要素データ成分2のラベル), (単位)

⋮

(各要素データ成分のラベル), (単位)
(要素番号1) (要素データ1) (要素データ2) ⋯
(要素番号2) (要素データ1) (要素データ2) ⋯

⋮

- Formulation of 3D Element
- 3D Heat Equations
 - Galerkin Method
 - Element Matrices
- Running the Code
- **Data Structure**
- Overview of the Program

Overview of Mesh File: cube.0

numbering starts from “1”

- Nodes
 - Node # (How many nodes ?)
 - Node ID, Coordinates
- Elements
 - Element #
 - Element Type
 - Element ID, Material ID, Connectivity
- Node Groups
 - Group #
 - Node # in each group
 - Group Name
 - Nodes in each group

Example of “cube.0” (NX=NY=NZ=4) Node

Node ID	X-coord.	Y	Z
125			
1	0.00	0.00	0.00
2	1.00	0.00	0.00
3	2.00	0.00	0.00
4	3.00	0.00	0.00
5	4.00	0.00	0.00
6	0.00	1.00	0.00
7	1.00	1.00	0.00
8	2.00	1.00	0.00
9	3.00	1.00	0.00
...			
121	0.00	4.00	4.00
122	1.00	4.00	4.00
123	2.00	4.00	4.00
124	3.00	4.00	4.00
125	4.00	4.00	4.00

=5*5*5 (Node #)

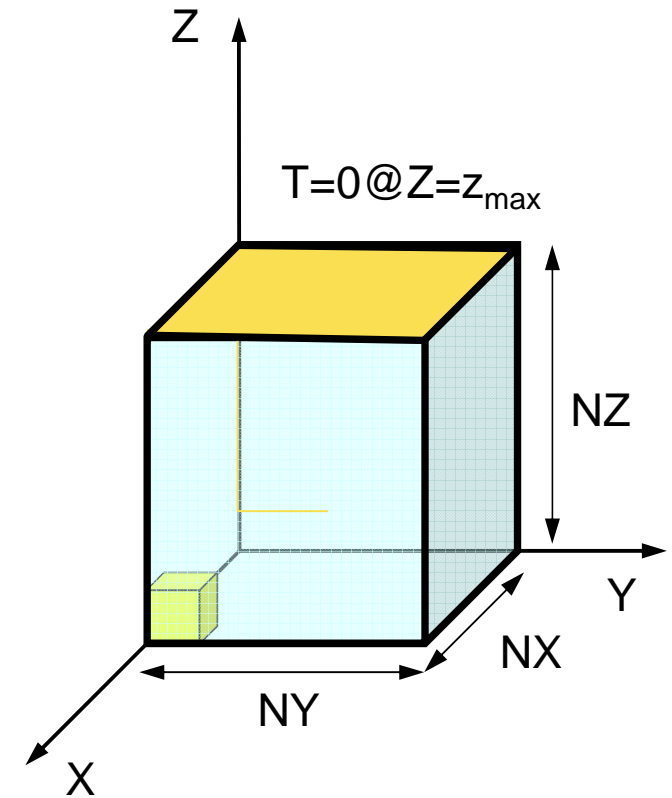

Example of “cube.0” (NX=NY=NZ=4) Element (1/2)

64												=4*4*4 (Element #)
361	361	361	361	361	361	361	361	361	361	361	361	361
361	361	361	361	361	361	361	361	361	361	361	361	361
361	361	361	361	361	361	361	361	361	361	361	361	361
361	361	361	361	361	361	361	361	361	361	361	361	361
361	361	361	361	361	361	361	361	361	361	361	361	361
361	361	361	361	361	361	361	361	361	361	361	361	361
361	361	361	361									

Element Type: 361
3D, Hexahedron, Linear (1st order)

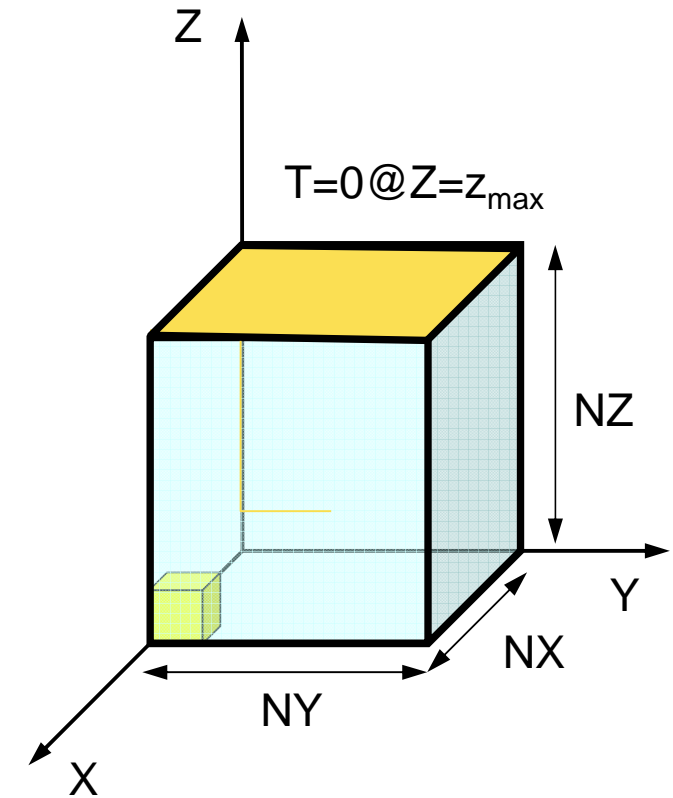

Example of “cube.0” Element (2/2)

1	1	1	2	7	6	26	27	32	31
2	1	2	3	8	7	27	28	33	32
3	1	3	4	9	8	28	29	34	33
4	1	4	5	10	9	29	30	35	34
5	1	6	7	12	11	31	32	37	36
6	1	7	8	13	12	32	33	38	37
7	1	8	9	14	13	33	34	39	38
8	1	9	10	15	14	34	35	40	39
9	1	11	12	17	16	36	37	42	41
10	1	12	13	18	17	37	38	43	42
11	1	13	14	19	18	38	39	44	43
12	1	14	15	20	19	39	40	45	44
13	1	16	17	22	21	41	42	47	46
...									
53	1	81	82	87	86	106	107	112	111
54	1	82	83	88	87	107	108	113	112
55	1	83	84	89	88	108	109	114	113
56	1	84	85	90	89	109	110	115	114
57	1	86	87	92	91	111	112	117	116
58	1	87	88	93	92	112	113	118	117
59	1	88	89	94	93	113	114	119	118
60	1	89	90	95	94	114	115	120	119
61	1	91	92	97	96	116	117	122	121
62	1	92	93	98	97	117	118	123	122
63	1	93	94	99	98	118	119	124	123
64	1	94	95	100	99	119	120	125	124

Elem ID MAT-ID

ID of 8 nodes

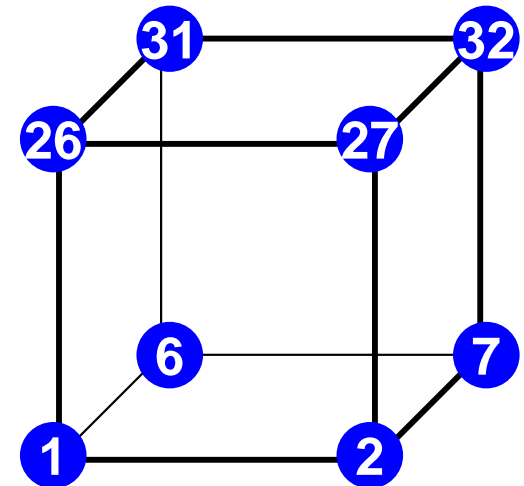
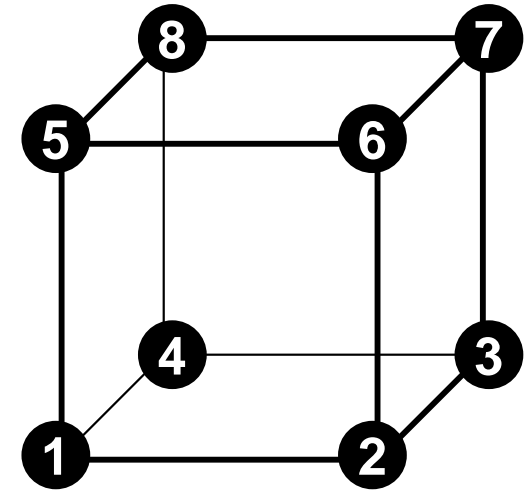

$$NX=NY=NZ=4, \quad NXP1=NYP1=NZP1=5$$

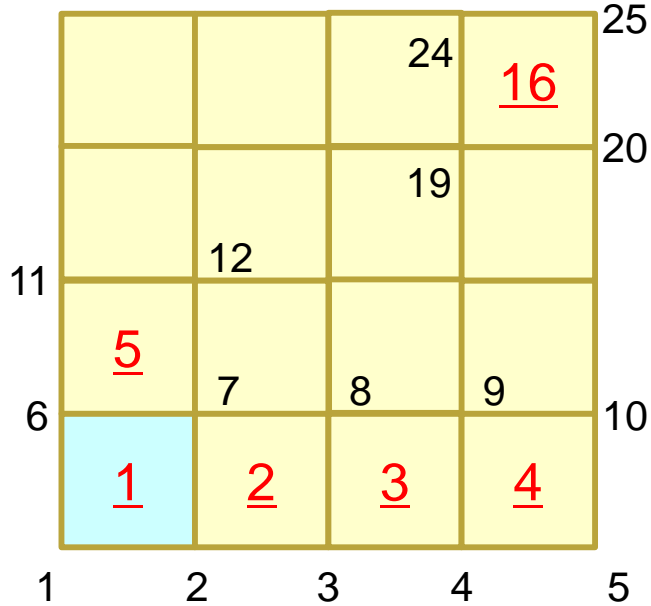
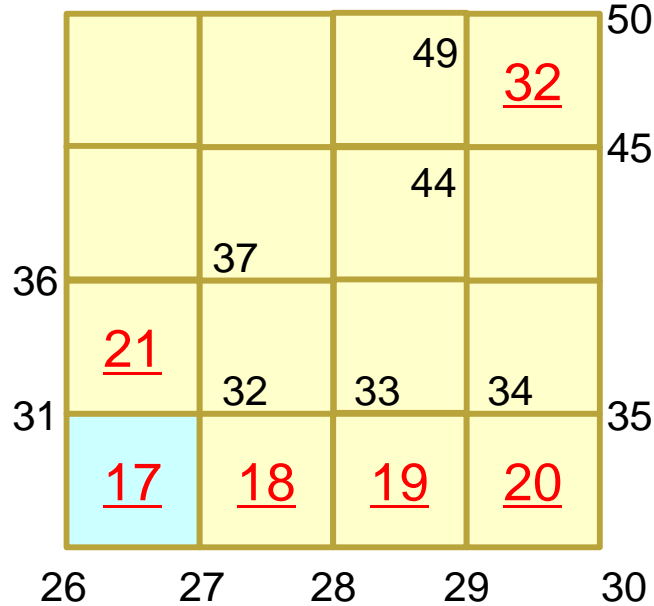
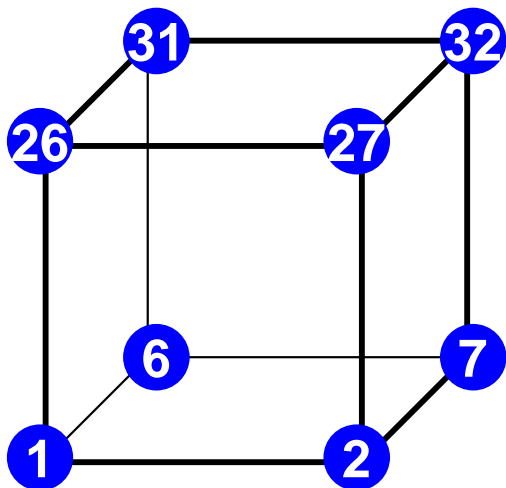
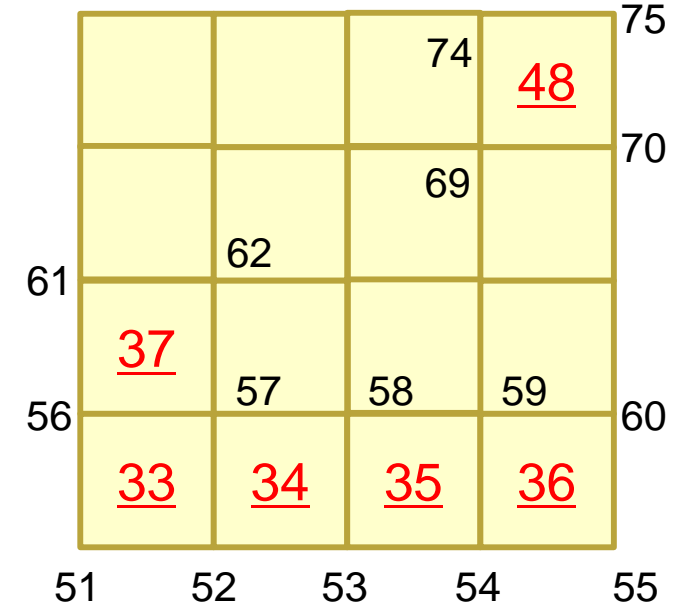
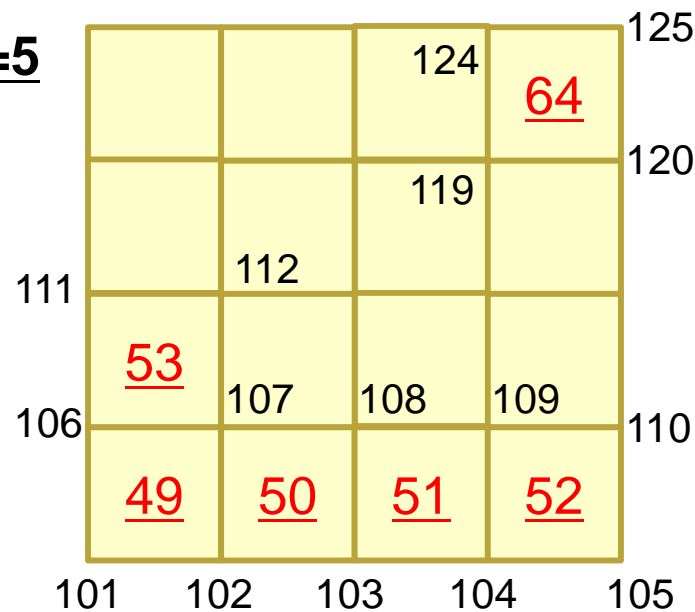
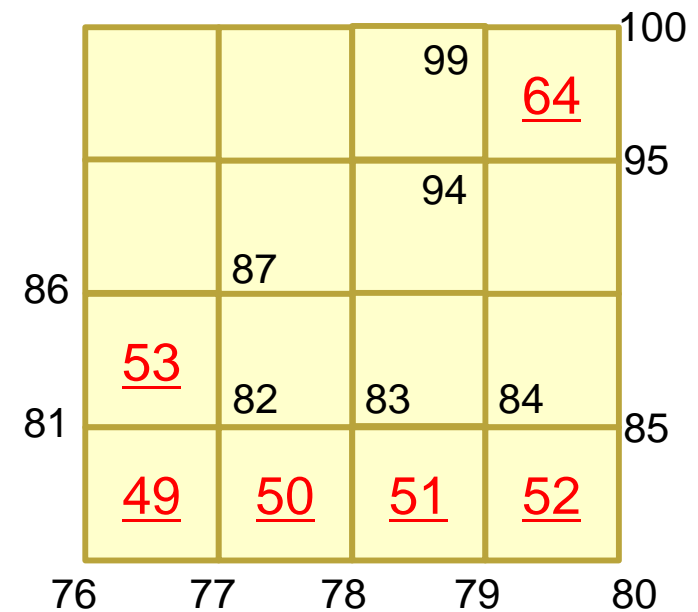
$$ICELTOT=64, \quad INODTOT=125, \quad IBNODTOT=25$$
k=1**k=2****k=3****k=5****k=4**

Example of “cube.0” Node Grp. Info.

	4	50	75	100	Number of Groups Number of Nodes (ea. grp.)					
Xmin	1	6	11	16	21	26	31	36	41	46
	51	56	61	66	71	76	81	86	91	96
	101	106	111	116	121					
Ymin	1	2	3	4	5	26	27	28	29	30
	51	52	53	54	55	76	77	78	79	80
	101	102	103	104	105					
Zmin	1	2	3	4	5	6	7	8	9	10
	11	12	13	14	15	16	17	18	19	20
	21	22	23	24	25					
Zmax	101	102	103	104	105	106	107	108	109	110
	111	112	113	114	115	116	117	118	119	120
	121	122	123	124	125					
no use after this line										

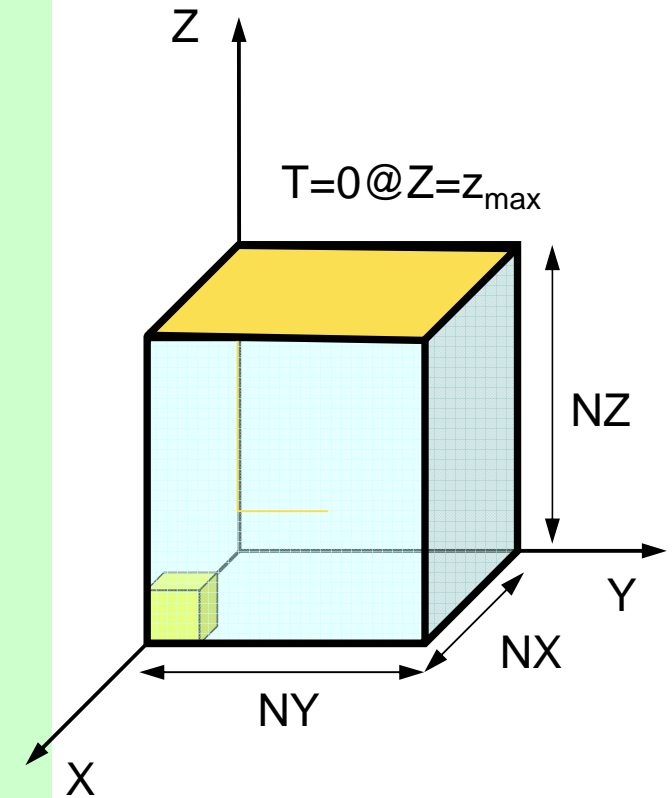

$NX=NY=NZ=4$, $NXP1=NYP1=NZP1=5$

$ICELTOT=64$, $INODTOT=125$, $IBNODTOT=25$

k=1

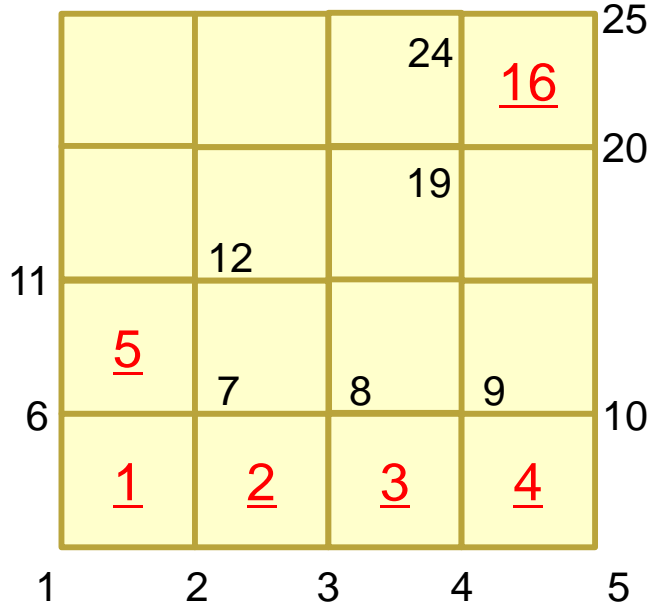

k=2

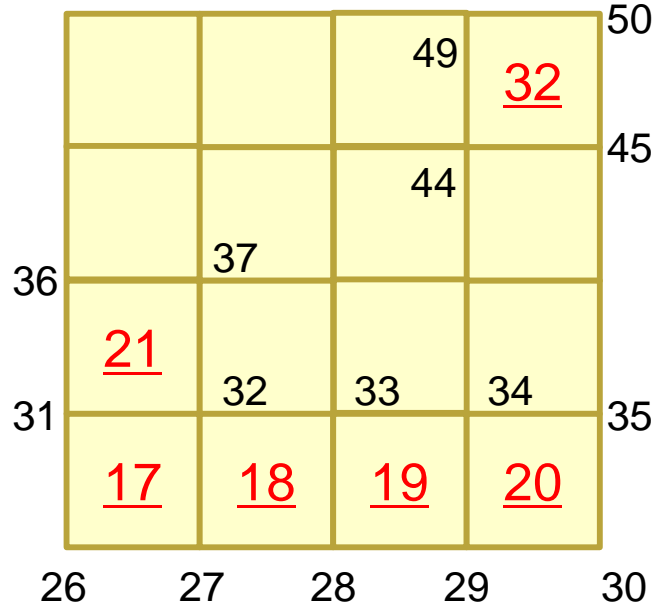

k=3

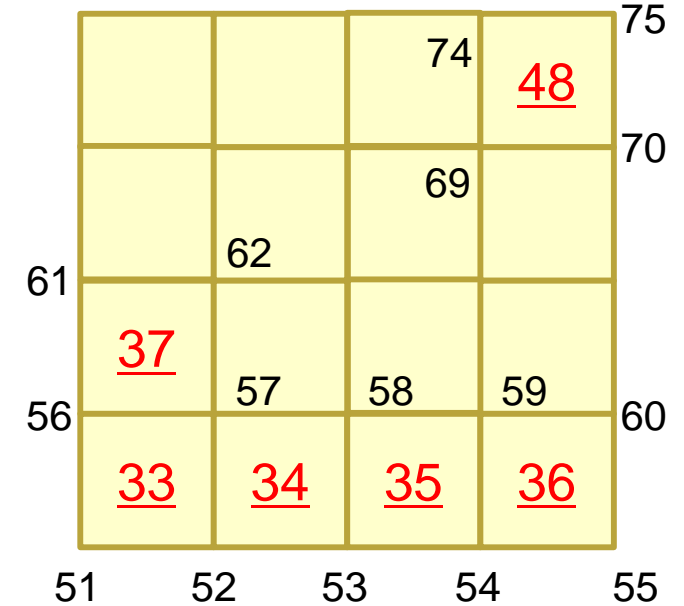

k=5

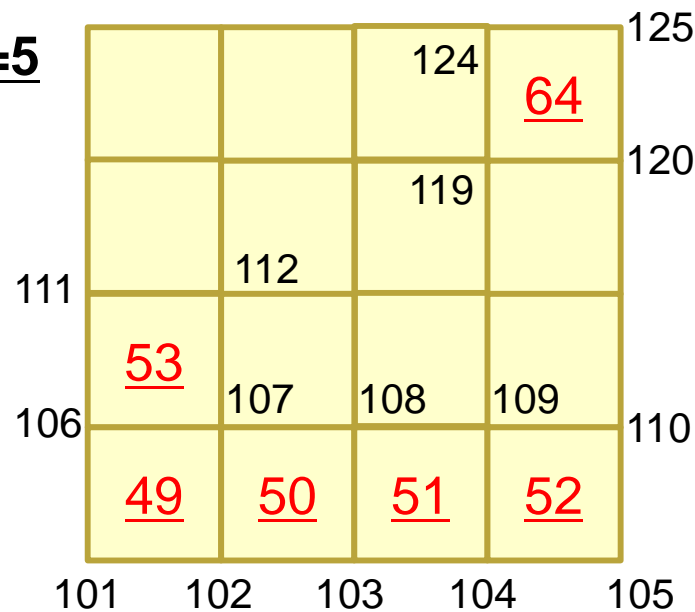

k=4

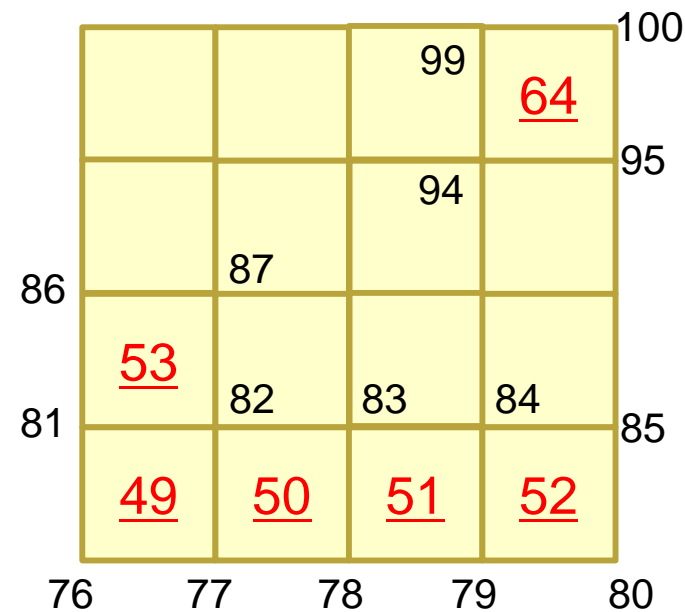

Xmin: i=1
Ymin: j=1
Zmin: k=1
Zmax: k=5

Mesh Generation

- Big Technical & Research Issue
 - Complicated Geometry
 - Large Scale
- Parallelization is difficult
- Commercial Mesh Generator
 - FEMAP
 - Interface to CAD Data Format



movie

- Formulation of 3D Element
- 3D Heat Equations
 - Galerkin Method
 - Element Matrices
- Running the Code
- Data Structure
- **Overview of the Program**

FEM Procedures: Program

- Initialization
 - Control Data
 - Node, Connectivity of Elements (N: Node#, NE: Elem#)
 - Initialization of Arrays (Global/Element Matrices)
 - Element-Global Matrix Mapping (Index, Item)
- Generation of Matrix
 - Element-by-Element Operations (do icel= 1, NE)
 - Element matrices
 - Accumulation to global matrix
 - Boundary Conditions
- Linear Solver
 - Conjugate Gradient Method

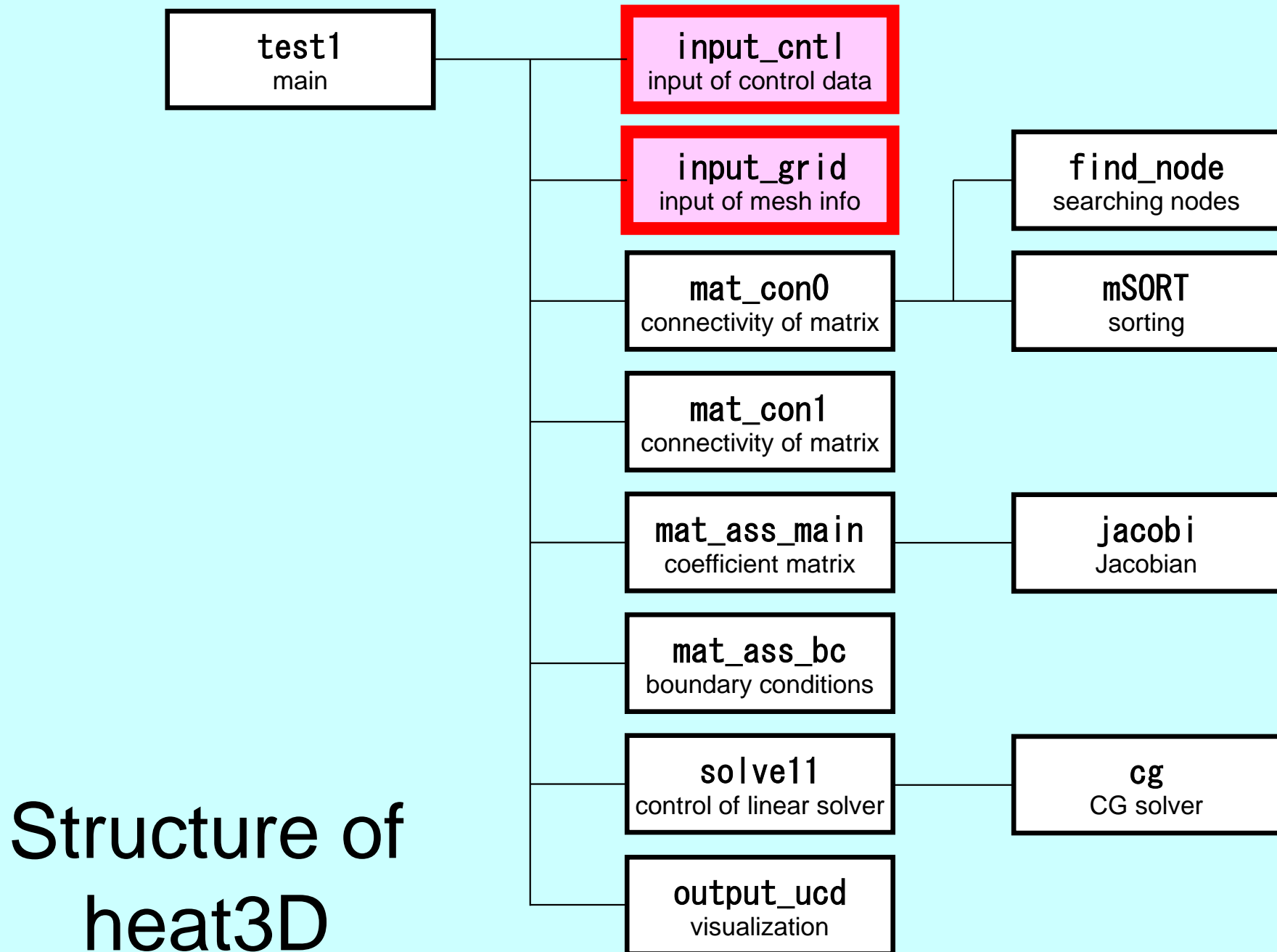

Main Part

```
program heat3D

use solver11
use pfem_util

implicit REAL*8 (A-H, O-Z)

call INPUT_CNTL
call INPUT_GRID

call MAT_CONO
call MAT_CON1

call MAT_ASS_MAIN
call MAT_ASS_BC

call SOLVE11

call OUTPUT_UCD

do i= 1, N
  if (XYZ(i, 1).eq. 0. d0. and. XYZ(i, 2).eq. 0. d0
&      .and. XYZ(i, 3).eq. 0. d0) then
    write (*, '(i8, 1pe16.6)') i, X(i)
  endif
enddo

end program heat3D
```

Global Variables: pfem_util.f (1/3)

Name	Type	Size	I/O	Definition
fname	C	(80)	I	Name of mesh file
N, NP	I		I	# Node
ICELTOT	I		I	# Element
NODGRPtot	I		I	# Node Group
XYZ	R	(N, 3)	I	Node Coordinates
ICELNOD	I	(ICELTOT, 8)	I	Element Connectivity
NODGRP_INDEX	I	(0:NODGRPtot)	I	# Node in each Node Group
NODGRP_ITEM	I	(NODGRP_INDEX(NODGRPtot))	I	Node ID in each Node Group
NODGRP_NAME	C80	(NODGRP_INDEX(NODGRPtot))	I	Name of NodeGroup
NLU	I		O	# Non-Zero Off-Diagonals at each node
NPLU	I		O	# Non-Zero Off-Diagonals
D	R	(N)	O	Diagonal Block of Global Matrix
B, X	R	(N)	O	RHS, Unknown Vector

Global Variables: pfem_util.h (2/3)

Name	Type	Size	I/O	Definition
AMAT	R	(NPLU)	○	Non-Zero Off-Diagonal Components of Global Matrix
index	I	(0:N)	○	# Non-Zero Off-Diagonal Components
item	I	(NPLU)	○	Column ID of Non-Zero Off-Diagonal Components
INLU	I	(N)	○	Number of Non-Zero Off-Diagonal Components at Each Node
IALU	I	(N,NLU)	○	Column ID of Non-Zero Off-Diagonal Components at Each Node
IWKX	I	(N,2)	○	Work Arrays
ITER, ITERactual	I		I	Number of CG Iterations (MAX, Actual)
RESID	R		I	Convergence Criteria (fixed as 1.e-8)
pfemIarray	I	(100)	○	Integer Parameter Array
pfemRarray	R	(100)	○	Real Parameter Array

Global Variables: pfem_util.h (3/3)

Name	Type	Size	I/O	Definition
O8th	R		I	= 0.125
PNQ, PNE, PNT	R	(2 , 2 , 8)	O	$\frac{\partial N_i}{\partial \xi}, \frac{\partial N_i}{\partial \eta}, \frac{\partial N_i}{\partial \zeta} (i=1 \sim 8)$ at each Gaussian Quad. Point
POS, WEI	R	(2)	O	Coordinates, Weighting Factor at each Gaussian Quad. Point
NCOL1, NCOL2	I	(100)	O	Work arrays for sorting
SHAPE	R	(2 , 2 , 2 , 8)	O	$N_i (i=1 \sim 8)$ at each Gaussian Quad Point
PNX, PNY, PNZ	R	(2 , 2 , 2 , 8)	O	$\frac{\partial N_i}{\partial x}, \frac{\partial N_i}{\partial y}, \frac{\partial N_i}{\partial z} (i=1 \sim 8)$ at each Gaussian Quad. Point
DETJ	R	(2 , 2 , 2)	O	Determinant of Jacobian Matrix at each Gaussian Quad. Point
COND, QVOL	R		I	Thermal Conductivity, Heat Generation Rate

$$\frac{\partial}{\partial x} \left(\lambda \frac{\partial T}{\partial x} \right) + \frac{\partial}{\partial y} \left(\lambda \frac{\partial T}{\partial y} \right) + \frac{\partial}{\partial z} \left(\lambda \frac{\partial T}{\partial z} \right) + \dot{Q}(x, y, z) = 0$$

$$\dot{Q}(x, y, z) = QVOL |x_c + y_c|$$

INPUT_CNTL: Control Data

```
subroutine INPUT_CNTL
use pfem_util

implicit REAL*8 (A-H,O-Z)

  open (11,file= ' INPUT.DAT', status='unknown')
  read (11,'(a80)') fname
  read (11,*) ITER
  read (11,*) COND, QVOL
  read (11,*) RESID
  close (11)

  pfemIarray(1)= ITER
  pfemRarray(1)= RESID

  return
end
```

INPUT.DAT

cube.0	fname
2000	ITER
1.0 1.0	COND, QVOL
1.0e-08	RESID

INPUT_GRID (1/3)

```
!C***
!C*** INPUT_GRID
!C***
!C
  subroutine INPUT_GRID
  use pfem_util
  implicit REAL*8 (A-H, O-Z)

  open (11, file= fname, status= 'unknown', form= 'formatted')

!C
!C-- NODE
  read (11,*) N
  NP= N

  allocate (XYZ(N, 3))
  XYZ= 0.d0
  do i= 1, N
    read (11,*) ii, (XYZ(i, kk), kk=1, 3)
  enddo
```

Example of “cube.0” Node

125				= N
1	0.00	0.00	0.00	
2	1.00	0.00	0.00	
3	2.00	0.00	0.00	
4	3.00	0.00	0.00	
5	4.00	0.00	0.00	
6	0.00	1.00	0.00	
7	1.00	1.00	0.00	
8	2.00	1.00	0.00	
9	3.00	1.00	0.00	
...				
121	0.00	4.00	4.00	
122	1.00	4.00	4.00	
123	2.00	4.00	4.00	
124	3.00	4.00	4.00	
125	4.00	4.00	4.00	

XYZ (i, 3)

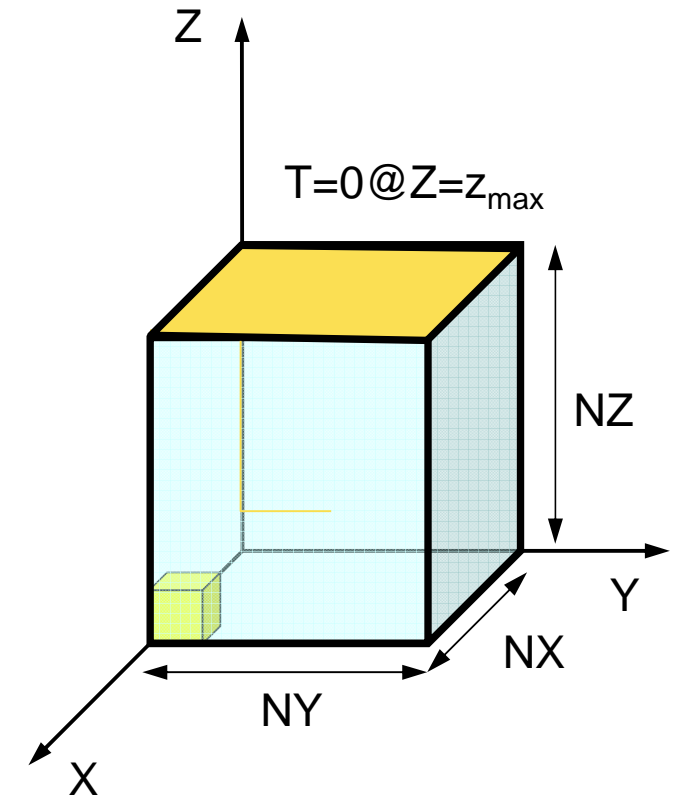

allocate, deallocate (1/2)

Same interface with FORTRAN

```
#include <stdio.h>
#include <stdlib.h>

void* allocate_vector(int size, int m)
{
    void *a;
    if ( ( a=(void * )malloc( m * size ) ) == NULL ) {
        fprintf(stdout, "Error:Memory does not enough! in vector %n");
        exit(1);
    }
    return a;
}

void deallocate_vector(void *a)
{
    free( a );
}
```

```
INDEX=(KINT* ) allocate_vector (sizeof (KINT), NGtot+1); INDEX[NGtot+1]
NAME =(CHAR80*) allocate_vector (sizeof (CHAR80), NGtot); NAME[NGtot]
WW=(KREAL**) allocate_matrix (sizeof (KREAL), 4, N); WW[4] [N]
```

allocate, deallocate (2/2)

Same interface with FORTRAN

```

void** allocate_matrix(int size, int m, int n)
{
    void **aa;
    int i;
    if ( ( aa=(void **)malloc( m * sizeof(void*) ) ) == NULL ) {
        fprintf(stdout, "Error:Memory does not enough! aa in matrix %n");
        exit(1);
    }
    if ( ( aa[0]=(void * )malloc( m * n * size ) ) == NULL ) {
        fprintf(stdout, "Error:Memory does not enough! in matrix %n");
        exit(1);
    }
    for (i=1; i<m; i++) aa[i]=(char*)aa[i-1]+size*n;
    return aa;
}

void deallocate_matrix(void **aa)
{
    free( aa );
}

```

```

INDEX=(KINT* ) allocate_vector (sizeof (KINT), NGtot+1); INDEX[NGtot+1]
NAME =(CHAR80*) allocate_vector (sizeof (CHAR80), NGtot); NAME [NGtot]
WW=(KREAL**) allocate_matrix (sizeof (KREAL), 4, N); WW [4] [N]

```

INPUT_GRID (2/3)

```
!C
!C-- ELEMENT
      read (11,*) ICELTOT
      allocate (ICELNOD(ICELTOT,8))
      read (11,'(10i10)') (NTYPE, i= 1, ICELTOT)

      do icel= 1, ICELTOT
        read (11,'(10i10,2i5,8i8)') ii, IMAT, (ICELNOD(icel,k), k=1,8)
      enddo
```

Example of “cube.0” Element (1/2)

64

= ICELTOT

```

361 361 361 361 361 361 361 361 361 361
361 361 361 361 361 361 361 361 361 361
361 361 361 361 361 361 361 361 361 361
361 361 361 361 361 361 361 361 361 361
361 361 361 361 361 361 361 361 361 361
361 361 361 361 361 361 361 361 361 361
361 361 361 361

```

Element Type: 361

3D, Hexahedron, Linear (1st order)

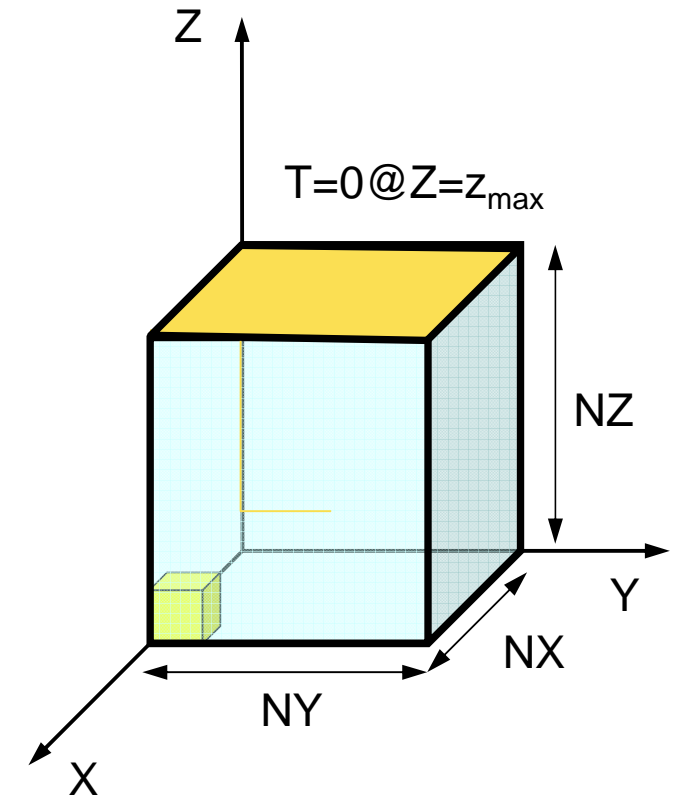

Example of “cube.0” Element (2/2)

1	1	1	2	7	6	26	27	32	31
2	1	2	3	8	7	27	28	33	32
3	1	3	4	9	8	28	29	34	33
4	1	4	5	10	9	29	30	35	34
5	1	6	7	12	11	31	32	37	36
6	1	7	8	13	12	32	33	38	37
7	1	8	9	14	13	33	34	39	38
8	1	9	10	15	14	34	35	40	39
9	1	11	12	17	16	36	37	42	41
10	1	12	13	18	17	37	38	43	42
11	1	13	14	19	18	38	39	44	43
12	1	14	15	20	19	39	40	45	44
13	1	16	17	22	21	41	42	47	46
...									
53	1	81	82	87	86	106	107	112	111
54	1	82	83	88	87	107	108	113	112
55	1	83	84	89	88	108	109	114	113
56	1	84	85	90	89	109	110	115	114
57	1	86	87	92	91	111	112	117	116
58	1	87	88	93	92	112	113	118	117
59	1	88	89	94	93	113	114	119	118
60	1	89	90	95	94	114	115	120	119
61	1	91	92	97	96	116	117	122	121
62	1	92	93	98	97	117	118	123	122
63	1	93	94	99	98	118	119	124	123
64	1	94	95	100	99	119	120	125	124

iMAT

ICELNOD(iceI, 8)

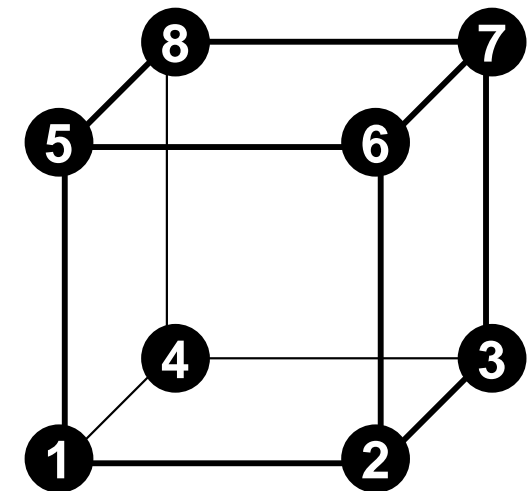
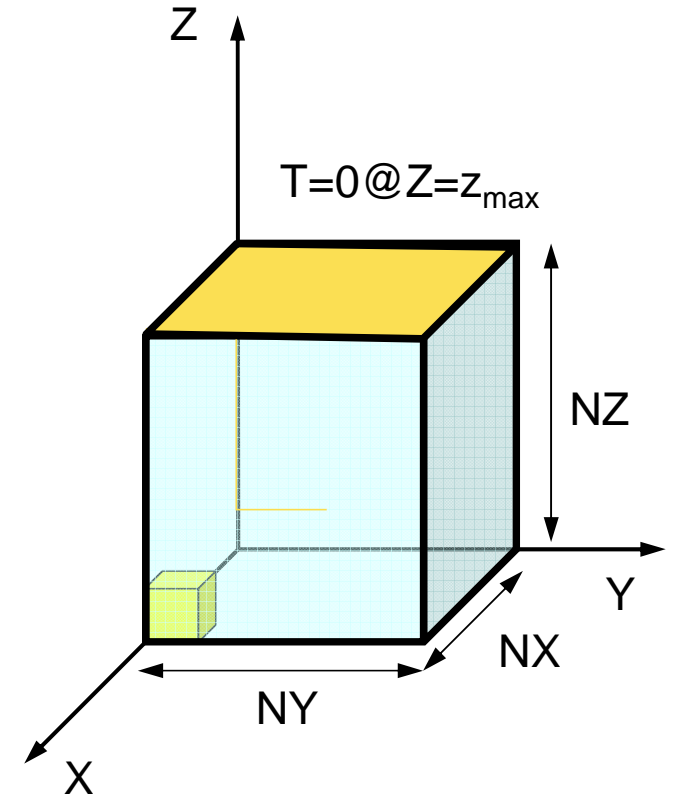

INPUT_GRID (3/3)

```
!C
!C-- NODE grp. info.
  read (11, '(10i10)') NODGRPtot
  allocate (NODGRP_INDEX(0:NODGRPtot), NODGRP_NAME(NODGRPtot))
  NODGRP_INDEX= 0

  read (11, '(10i10)') (NODGRP_INDEX(i), i= 1, NODGRPtot)
  nn= NODGRP_INDEX(NODGRPtot)
  allocate (NODGRP_ITEM(nn))

  do k= 1, NODGRPtot
    iS= NODGRP_INDEX(k-1) + 1
    iE= NODGRP_INDEX(k )
    read (11, '(a80)') NODGRP_NAME(k)
    nn= iE - iS + 1
    if (nn.ne.0) then
      read (11, '(10i10)') (NODGRP_ITEM(kk), kk=iS, iE)
    endif
  enddo

  close (11)

  return
end
```

Example of “cube.0” Node Grp. Info.

4
25 50 75 100

NODGRPtot
NODGRP_INDEX (1-4)

Xmin

NODGRP_NAME (1)
NODGRP_ITEM (1-25)

1 6 11 16 21 26 31 36 41 46
51 56 61 66 71 76 81 86 91 96
101 106 111 116 121

Ymin

NODGRP_NAME (2)
NODGRP_ITEM (26-50)

1 2 3 4 5 26 27 28 29 30
51 52 53 54 55 76 77 78 79 80
101 102 103 104 105

Zmin

NODGRP_NAME (3)
NODGRP_ITEM (51-75)

1 2 3 4 5 6 7 8 9 10
11 12 13 14 15 16 17 18 19 20
21 22 23 24 25

Zmax

NODGRP_NAME (4)
NODGRP_ITEM (76-100)

101 102 103 104 105 106 107 108 109 110
111 112 113 114 115 116 117 118 119 120
121 122 123 124 125

Structure of heat3D

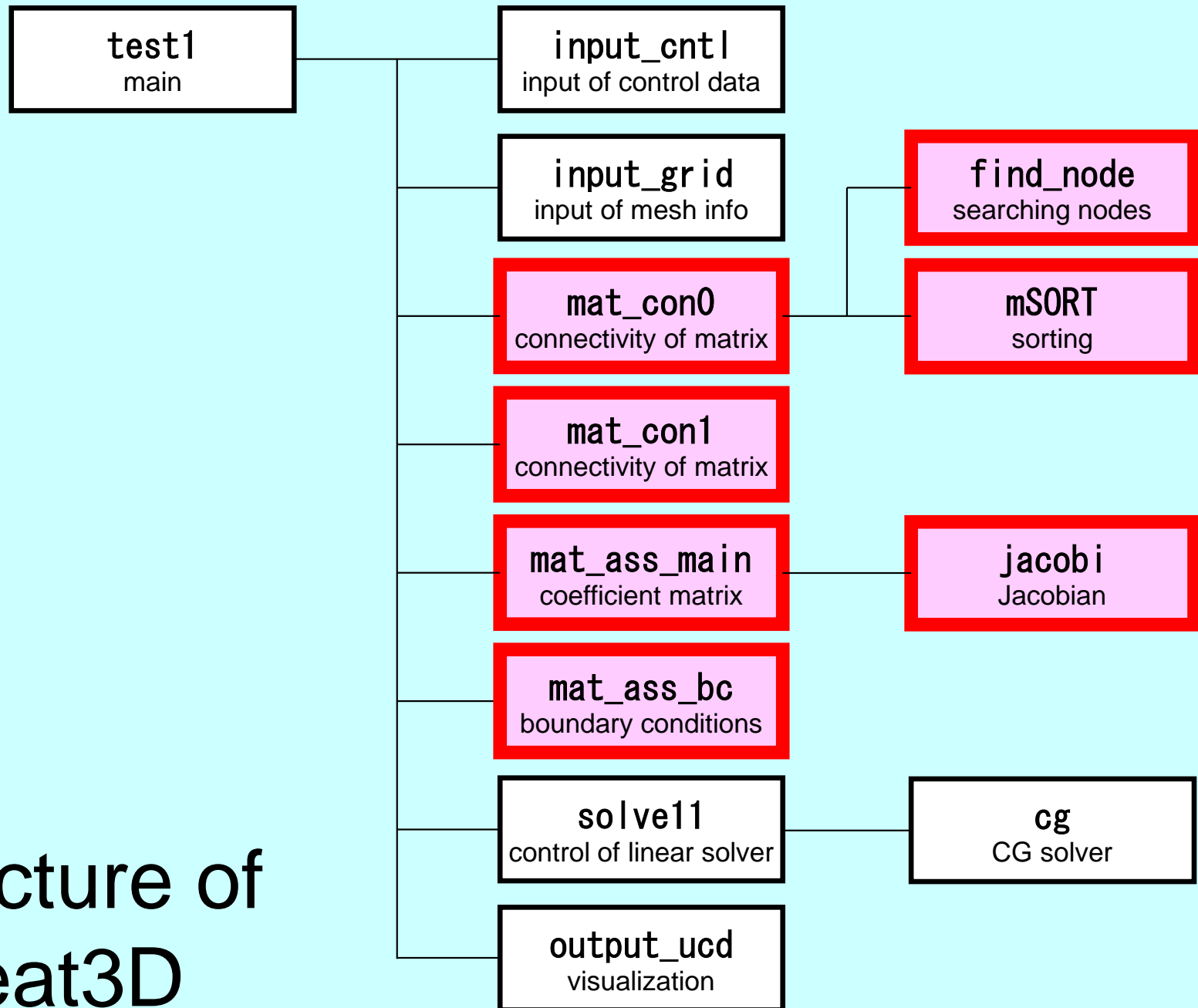

Global Variables: pfem_util.f (1/3)

Name	Type	Size	I/O	Definition
fname	C	(80)	I	Name of mesh file
N, NP	I		I	# Node
ICELTOT	I		I	# Element
NODGRPtot	I		I	# Node Group
XYZ	R	(N, 3)	I	Node Coordinates
ICELNOD	I	(ICELTOT, 8)	I	Element Connectivity
NODGRP_INDEX	I	(0:NODGRPtot)	I	# Node in each Node Group
NODGRP_ITEM	I	(NODGRP_INDEX(NODGRPtot))	I	Node ID in each Node Group
NODGRP_NAME	C80	(NODGRP_INDEX(NODGRPtot))	I	Name of NodeGroup
NLU	I		O	# Non-Zero Off-Diagonals at each node
NPLU	I		O	# Non-Zero Off-Diagonals
D	R	(N)	O	Diagonal Block of Global Matrix
B, X	R	(N)	O	RHS, Unknown Vector

Global Variables: pfem_util.f (2/3)

Name	Type	Size	I/O	Definition
AMAT	R	(NPLU)	O	Non-Zero Off-Diagonal Components of Global Matrix
index	I	(0:N)	O	# Non-Zero Off-Diagonal Components
item	I	(NPLU)	O	Column ID of Non-Zero Off-Diagonal Components
INLU	I	(N)	O	Number of Non-Zero Off-Diagonal Components at Each Node
IALU	I	(N,NLU)	O	Column ID of Non-Zero Off-Diagonal Components at Each Node
IWKX	I	(N,2)	O	Work Arrays
ITER, ITERactual	I		I	Number of CG Iterations (MAX, Actual)
RESID	R		I	Convergence Criteria (fixed as 1.e-8)
pfemIarray	I	(100)	O	Integer Parameter Array
pfemRarray	R	(100)	O	Real Parameter Array

Global Variables: pfem_util.f (3/3)

Name	Type	Size	I/O	Definition
O8th	R		I	= 0.125
PNQ, PNE, PNT	R	(2 , 2 , 8)	O	$\frac{\partial N_i}{\partial \xi}, \frac{\partial N_i}{\partial \eta}, \frac{\partial N_i}{\partial \zeta} (i=1 \sim 8)$ at each Gaussian Quad. Point
POS, WEI	R	(2)	O	Coordinates, Weighting Factor at each Gaussian Quad. Point
NCOL1, NCOL2	I	(100)	O	Work arrays for sorting
SHAPE	R	(2 , 2 , 2 , 8)	O	$N_i (i=1 \sim 8)$ at each Gaussian Quad Point
PNX, PNY, PNZ	R	(2 , 2 , 2 , 8)	O	$\frac{\partial N_i}{\partial x}, \frac{\partial N_i}{\partial y}, \frac{\partial N_i}{\partial z} (i=1 \sim 8)$ at each Gaussian Quad. Point
DETJ	R	(2 , 2 , 2)	O	Determinant of Jacobian Matrix at each Gaussian Quad. Point
COND, QVOL	R		I	Thermal Conductivity, Heat Generation Rate

$$\frac{\partial}{\partial x} \left(\lambda \frac{\partial T}{\partial x} \right) + \frac{\partial}{\partial y} \left(\lambda \frac{\partial T}{\partial y} \right) + \frac{\partial}{\partial z} \left(\lambda \frac{\partial T}{\partial z} \right) + \dot{Q}(x, y, z) = 0$$

$$\dot{Q}(x, y, z) = QVOL |x_c + y_c|$$

Towards Matrix Assembling

- In 1D, it was easy to obtain information related to index and item.
 - 2 non-zero off-diagonals for each node
 - ID of non-zero off-diagonal : $i+1$, $i-1$, where “ i ” is node ID
- In 3D, situation is more complicated:
 - Number of non-zero off-diagonal components is between 7 and 26 for the current target problem
 - More complicated for real problems.
 - Generally, there are no information related to number of non-zero off-diagonal components beforehand.

Towards Matrix Assembling

- In 1D, it was easy to obtain information related to index and item.
 - 2 non-zero off-diagonals for each node
 - ID of non-zero off-diagonal : $i+1$, $i-1$, where “ i ” is node ID
- In 3D, situation is more complicated:
 - Number of non-zero off-diagonal components is between 7 and 26 for the current target problem
 - More complicated for real problems.
 - Generally, there are no information related to number of non-zero off-diagonal components beforehand.
- **Count number of non-zero off-diagonals using arrays: $INLU[N]$, $IALU[N][NLU]$**

Main Part

```

program heat3D

use solver11
use pfem_util

implicit REAL*8(A-H, O-Z)

call INPUT_CNTL
call INPUT_GRID

call MAT_CON0
call MAT_CON1

call MAT_ASS_MAIN
call MAT_ASS_BC

call SOLVE11

call OUTPUT_UCD

end program heat3D

```

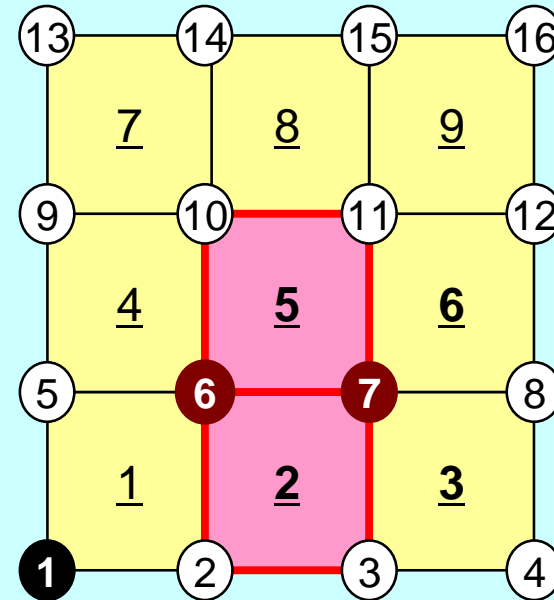

MAT_CON0: generates INU, IALU
 MAT_CON1: generates index, item

Node ID starting from “1”

MAT_CON0: Overview

```
do icel= 1, ICELTOT
  generate INLU, IALU
  according to 8 nodes of hex. elements
  (FIND_NODE)
enddo
```

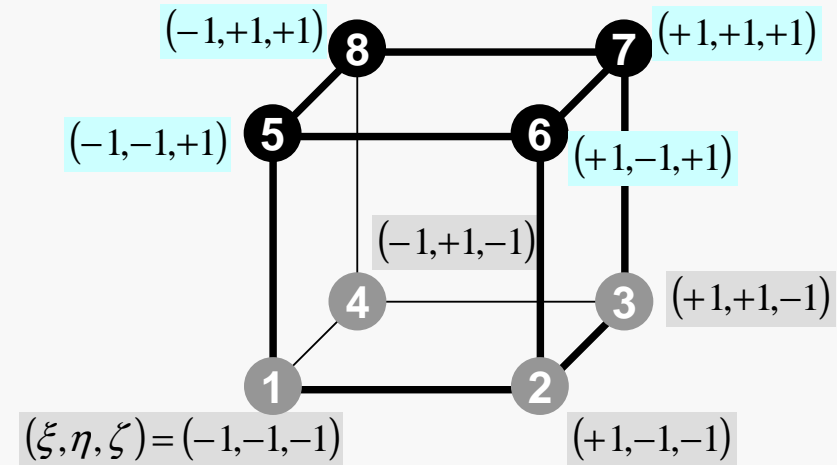
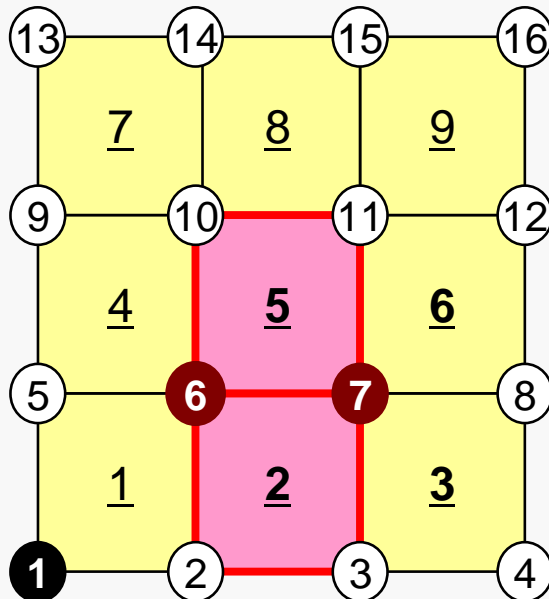

Generating Connectivity of Matrix MAT_CONO (1/4)

```
!C
!C***
!C*** MAT_CONO
!C***
!C
  subroutine MAT_CONO
  use pfem_util
  implicit REAL*8 (A-H, O-Z)

  NLU= 26

  allocate (INLU(N), IALU(N, NLU))

  INLU= 0
  IALU= 0
```

NLU:

Number of maximum number of connected nodes to each node (number of upper/lower non-zero off-diagonal nodes)

In the current problem, geometry is rather simple. Therefore we can specify NLU in this way.

If it's not clear ->
Try more flexible implementation

Why $NLU=26$?

Max Number of Neighboring Nodes

$$9+8+9= 26$$

NLU:

Number of maximum number of connected nodes to each node (number of upper/lower non-zero off-diagonal nodes)

In the current problem, geometry is rather simple. Therefore we can specify NLU in this way.

If it's not clear ->
Try more flexible implementation

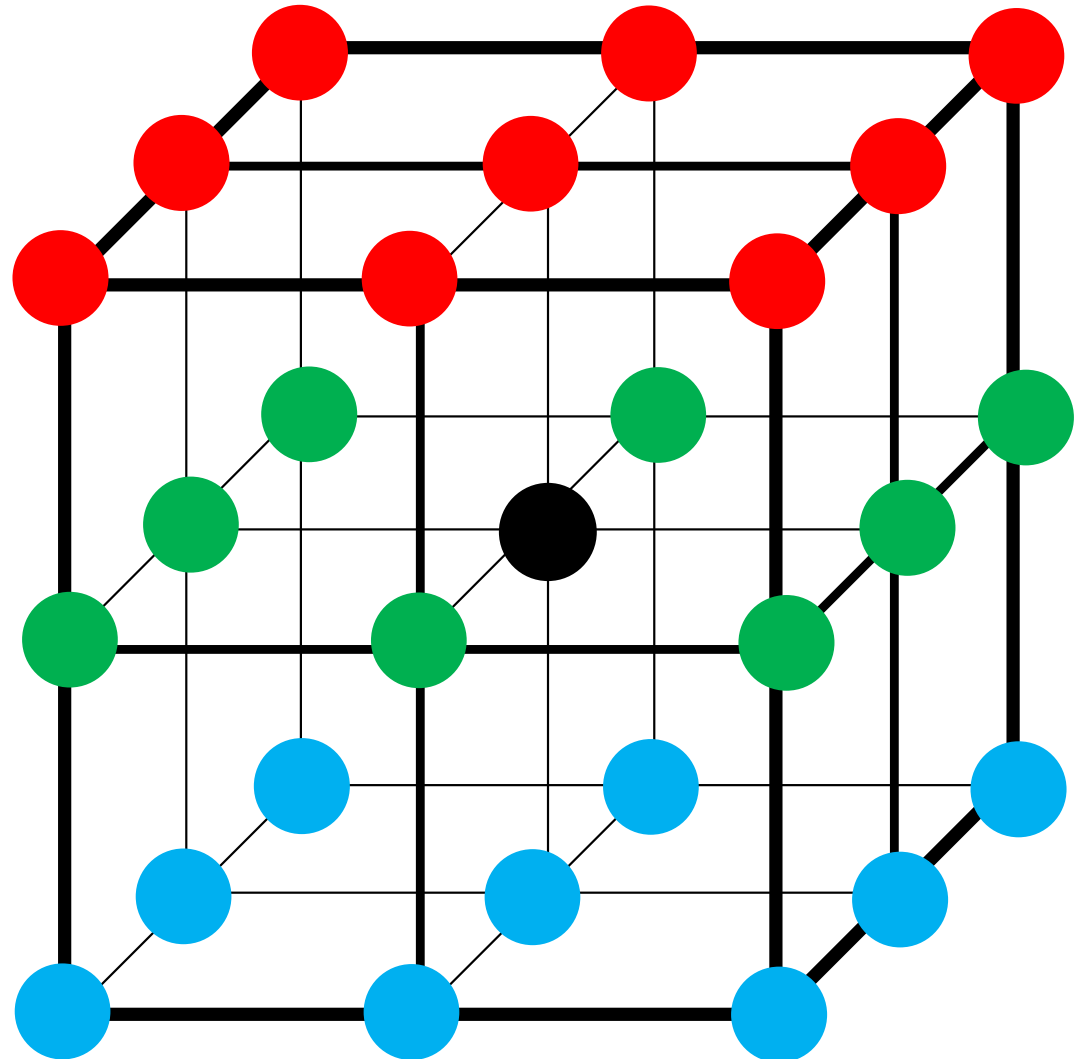

Generating Connectivity of Matrix MAT_CON0 (1/4)

```
!C
!C***
!C*** MAT_CON0
!C***
!C
      subroutine MAT_CON0
      use pfem_util
      implicit REAL*8 (A-H, O-Z)

      NLU= 26

      allocate (INLU(N), IALU(N, NLU))

      INLU= 0
      IALU= 0
```

Array	Size	Description
INLU	(N)	Number of connected nodes to each node (lower/upper)
IALU	(N, NLU)	Corresponding connected node ID (column ID)

Generating Connectivity of Matrix MAT_CON0 (2/4): Starting from 1

```

do icel= 1, ICELTOT
  in1= ICELNOD (icel, 1)
  in2= ICELNOD (icel, 2)
  in3= ICELNOD (icel, 3)
  in4= ICELNOD (icel, 4)
  in5= ICELNOD (icel, 5)
  in6= ICELNOD (icel, 6)
  in7= ICELNOD (icel, 7)
  in8= ICELNOD (icel, 8)

  call FIND_TS_NODE (in1, in2)
  call FIND_TS_NODE (in1, in3)
  call FIND_TS_NODE (in1, in4)
  call FIND_TS_NODE (in1, in5)
  call FIND_TS_NODE (in1, in6)
  call FIND_TS_NODE (in1, in7)
  call FIND_TS_NODE (in1, in8)

  call FIND_TS_NODE (in2, in1)
  call FIND_TS_NODE (in2, in3)
  call FIND_TS_NODE (in2, in4)
  call FIND_TS_NODE (in2, in5)
  call FIND_TS_NODE (in2, in6)
  call FIND_TS_NODE (in2, in7)
  call FIND_TS_NODE (in2, in8)

  call FIND_TS_NODE (in3, in1)
  call FIND_TS_NODE (in3, in2)
  call FIND_TS_NODE (in3, in4)
  call FIND_TS_NODE (in3, in5)
  call FIND_TS_NODE (in3, in6)
  call FIND_TS_NODE (in3, in7)
  call FIND_TS_NODE (in3, in8)

```

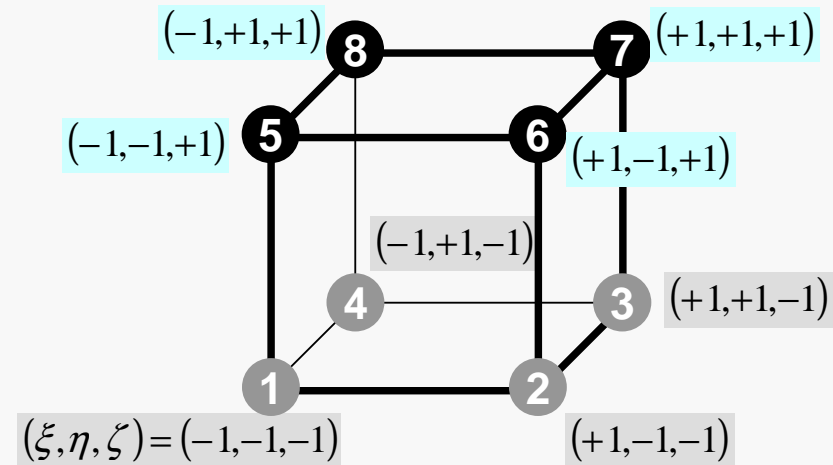

FIND_TS_NODE: Search Connectivity

INLU,IALU: Automatic Search

```
!C
!C***
!C*** FIND_TS_NODE
!C***
!C
      subroutine FIND_TS_NODE (ip1, ip2)

         do kk= 1, INLU(ip1)
            if (ip2.eq. IALU(ip1, kk)) return
         enddo
         icou= INLU(ip1) + 1
         IALU(ip1, icou)= ip2
         INLU(ip1      )= icou
         return

      end subroutine FIND_TS_NODE
```

Array	Size	Description
INLU	(N)	Number of connected nodes to each node (lower/upper)
IALU	(N, NLU)	Corresponding connected node ID (column ID)

FIND_TS_NODE: Search Connectivity

INLU,IALU: Automatic Search, #2 Element

```

!C
!C***
!C*** FIND_TS_NODE
!C***
!C
      subroutine FIND_TS_NODE (ip1, ip2)

        do kk= 1, INLU(ip1)
          if (ip2.eq. IALU(ip1, kk)) return
        enddo
        icou= INLU(ip1) + 1
        IALU(ip1, icou)= ip2
        INLU(ip1      )= icou
        return

      end subroutine FIND_TS_NODE
  
```

Checking whether “ip2”
is already included in
IALU(ip1, kk), or not

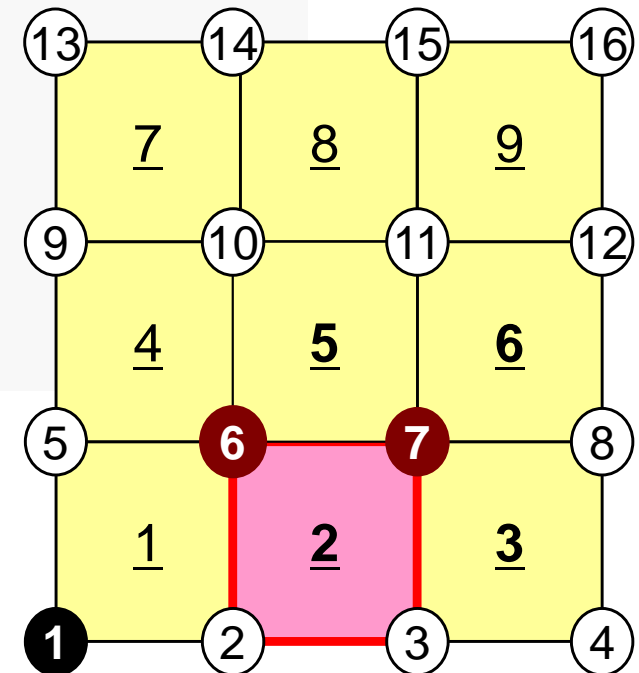

ip1: No.6 node
ip2: No.7 node

FIND_TS_NODE: Search Connectivity

INLU,IALU: Automatic Search, #2 Element

```
!C
!C***
!C*** FIND_TS_NODE
!C***
!C
subroutine FIND_TS_NODE (ip1, ip2)

do kk= 1, INLU(ip1)
  if (ip2.eq. IALU(ip1, kk)) return
enddo
  icou= INLU(ip1) + 1
  IALU(ip1, icou)= ip2
  INLU(ip1      )= icou
return

end subroutine FIND_TS_NODE
```

If the target node is NOT included in IALU, store the node in IALU, and add 1 to INLU.

ip1: No.6 node
ip2: No.7 node

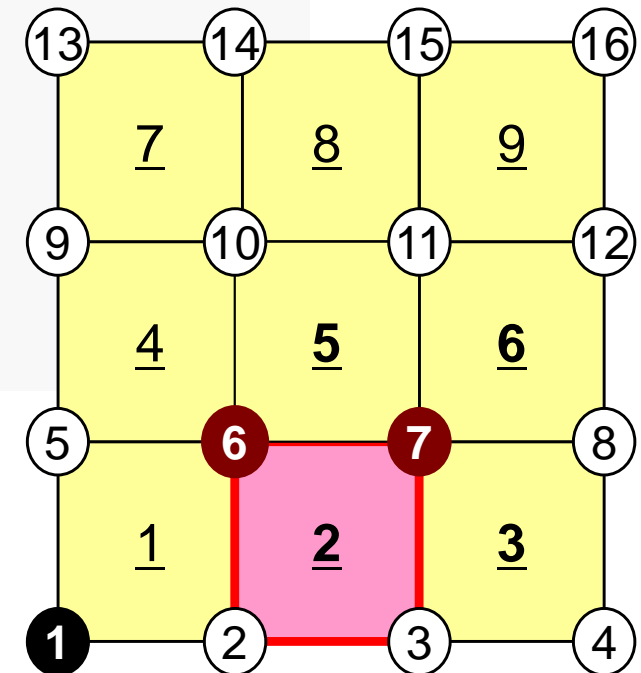

FIND_TS_NODE: Search Connectivity

INLU,IALU: Automatic Search, #5 Element

```
!C
!C***
!C*** FIND_TS_NODE
!C***
!C
  subroutine FIND_TS_NODE (ip1, ip2)

    do kk= 1, INLU(ip1)
      if (ip2.eq. IALU(ip1, kk)) return
    enddo
    icou= INLU(ip1) + 1
    IALU(ip1, icou)= ip2
    INLU(ip1      )= icou
    return

  end subroutine FIND_TS_NODE
```

ip1: No.6 node
ip2: No.7 node

If the target node is already included in IALU, proceed to next pair of nodes

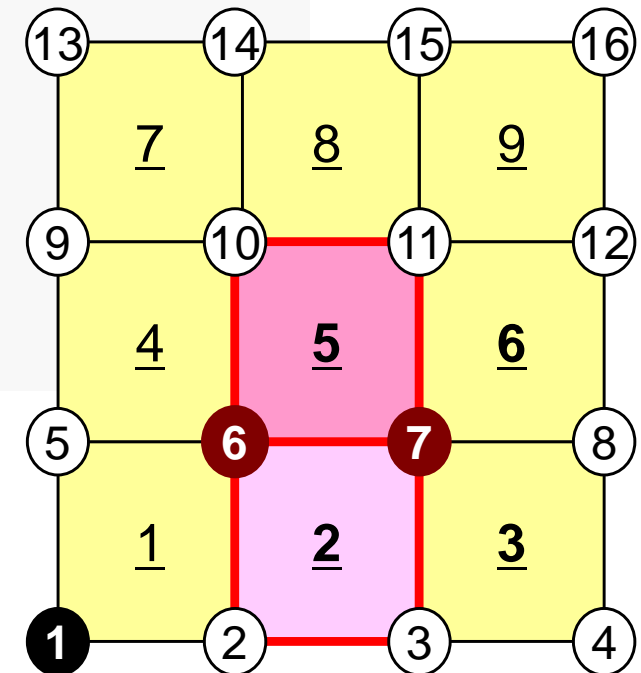

Generating Connectivity of Matrix MAT_CON0 (3/4)

```

call FIND_TS_NODE (in4, in1)
call FIND_TS_NODE (in4, in2)
call FIND_TS_NODE (in4, in3)
call FIND_TS_NODE (in4, in5)
call FIND_TS_NODE (in4, in6)
call FIND_TS_NODE (in4, in7)
call FIND_TS_NODE (in4, in8)

```

```

call FIND_TS_NODE (in5, in1)
call FIND_TS_NODE (in5, in2)
call FIND_TS_NODE (in5, in3)
call FIND_TS_NODE (in5, in4)
call FIND_TS_NODE (in5, in6)
call FIND_TS_NODE (in5, in7)
call FIND_TS_NODE (in5, in8)

```

```

call FIND_TS_NODE (in6, in1)
call FIND_TS_NODE (in6, in2)
call FIND_TS_NODE (in6, in3)
call FIND_TS_NODE (in6, in4)
call FIND_TS_NODE (in6, in5)
call FIND_TS_NODE (in6, in7)
call FIND_TS_NODE (in6, in8)

```

```

call FIND_TS_NODE (in7, in1)
call FIND_TS_NODE (in7, in2)
call FIND_TS_NODE (in7, in3)
call FIND_TS_NODE (in7, in4)
call FIND_TS_NODE (in7, in5)
call FIND_TS_NODE (in7, in6)
call FIND_TS_NODE (in7, in8)

```

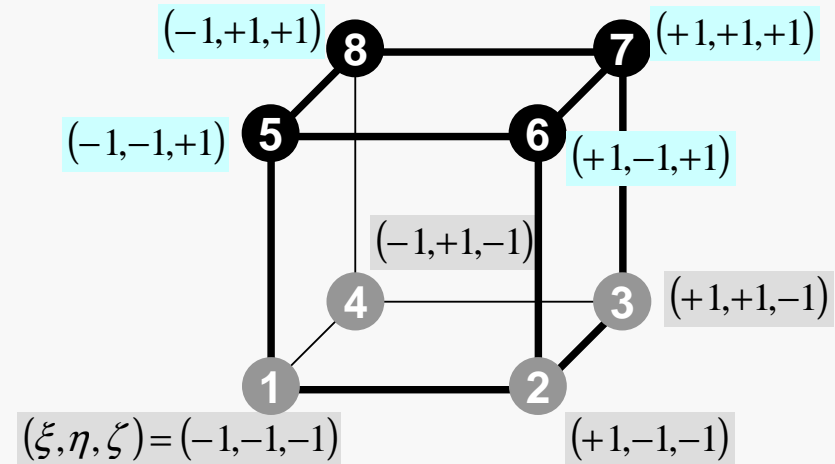

Generating Connectivity of Matrix MAT_CON0 (4/4)

```
call FIND_TS_NODE (in8, in1)
call FIND_TS_NODE (in8, in2)
call FIND_TS_NODE (in8, in3)
call FIND_TS_NODE (in8, in4)
call FIND_TS_NODE (in8, in5)
call FIND_TS_NODE (in8, in6)
call FIND_TS_NODE (in8, in7)
enddo
```

```
do in= 1, N
  NN= INLU(in)
  do k= 1, NN
    NCOL1(k) = IALU(in, k)
  enddo
  call mSORT (NCOL1, NCOL2, NN)
  do k= NN, 1, -1
    IALU(in, NN-k+1) = NCOL1(NCOL2(k))
  enddo
enddo
```

Sort IALU(i,k) in ascending order by “bubble” sorting for less than 100 components.

MAT_CON1: CRS format

```

!C
!C***
!C*** MAT_CON1
!C***
!C
      subroutine MAT_CON1
      use pfem_util
      implicit REAL*8 (A-H, O-Z)

      allocate (index(0:N))
      index= 0

      do i= 1, N
         index(i)= index(i-1) + INLU(i)
      enddo

      NPLU= index(N)

      allocate (item(NPLU))

      do i= 1, N
         do k= 1, INLU(i)
            kk = k + index(i-1)
            item(kk)= IALU(i, k)
         enddo
      enddo

      deallocate (INLU, IALU)

      end subroutine MAT_CON1

```

C

$$\text{index}[i+1] = \sum_{k=0}^i \text{INLU}[k]$$

$$\text{index}[0] = 0$$

FORTRAN

$$\text{index}(i) = \sum_{k=1}^i \text{INLU}(k)$$

$$\text{index}(0) = 0$$

MAT_CON1: CRS format

```

!C
!C***
!C*** MAT_CON1
!C***
!C
subroutine MAT_CON1
use pfem_util
implicit REAL*8 (A-H, O-Z)

allocate (index(0:N))
index= 0

do i= 1, N
  index(i)= index(i-1) + INLU(i)
enddo

NPLU= index(N)

allocate (item(NPLU))

do i= 1, N
  do k= 1, INLU(i)
    kk = k + index(i-1)
    item(kk)= IALU(i, k)
  enddo
enddo

deallocate (INLU, IALU)

end subroutine MAT_CON1

```

NPLU=index(N)
Size of array: item
Total number of non-zero off-diagonal blocks

MAT_CON1: CRS format

```

!C
!C***
!C*** MAT_CON1
!C***
!C
subroutine MAT_CON1
use pfem_util
implicit REAL*8 (A-H, O-Z)

allocate (index(0:N))
index= 0

do i= 1, N
  index(i)= index(i-1) + INLU(i)
enddo

NPLU= index(N)

allocate (item(NPLU))

do i= 1, N
  do k= 1, INLU(i)
    kk = k + index(i-1)
    item(kk)= IALU(i, k)
  enddo
enddo

deallocate (INLU, IALU)

end subroutine MAT_CON1

```

item

store node ID starting from 0

MAT_CON1: CRS format

```
!C
!C***
!C*** MAT_CON1
!C***
!C
subroutine MAT_CON1
use pfem_util
implicit REAL*8 (A-H, O-Z)

allocate (index(0:N))
index= 0

do i= 1, N
  index(i)= index(i-1) + INLU(i)
enddo

NPLU= index(N)

allocate (item(NPLU))

do i= 1, N
  do k= 1, INLU(i)
    kk = k + index(i-1)
    item(kk)= IALU(i, k)
  enddo
enddo

deallocate (INLU, IALU)

end subroutine MAT_CON1
```

Not required any more

Main Part

```
program heat3D

use solver11
use pfem_util

implicit REAL*8 (A-H, O-Z)

call INPUT_CNTL
call INPUT_GRID

call MAT_CON0
call MAT_CON1

call MAT_ASS_MAIN
call MAT_ASS_BC

call SOLVE11

call OUTPUT_UCD

do i= 1, N
  if (XYZ(i, 1).eq. 0. d0. and. XYZ(i, 2).eq. 0. d0
&      .and. XYZ(i, 3).eq. 0. d0) then
    write (*, '(i8, 1pe16.6)') i, X(i)
  endif
enddo

end program heat3D
```

MAT_ASS_MAIN: Overview

```

do kpn= 1, 2      Gaussian Quad. points in  $\zeta$ -direction
  do jpn= 1, 2    Gaussian Quad. points in  $\eta$ -direction
    do ipn= 1, 2  Gaussian Quad. Pointe in  $\xi$ -direction
      Define Shape Function at Gaussian Quad. Points (8-points)
      Its derivative on natural/local coordinate is also defined.
    enddo
  enddo
enddo

```

```

do icel= 1, ICELTOT  Loop for Element
  Jacobian and derivative on global coordinate of shape functions at
  Gaussian Quad. Points are defined according to coordinates of 8 nodes. (JACOBI)

```

```

do ie= 1, 8        Local Node ID
  do je= 1, 8      Local Node ID
    Global Node ID: ip, jp
    Address of  $A_{ip, jp}$  in "item" : kk

```

```

do kpn= 1, 2      Gaussian Quad. points in  $\zeta$ -direction
  do jpn= 1, 2    Gaussian Quad. points in  $\eta$ -direction
    do ipn= 1, 2  Gaussian Quad. points in  $\xi$ -direction
      integration on each element
      coefficients of element matrices
      accumulation to global matrix

```

```

    enddo

```

```

  enddo

```

```

enddo

```

```

enddo

```

```

enddo

```

```

enddo

```

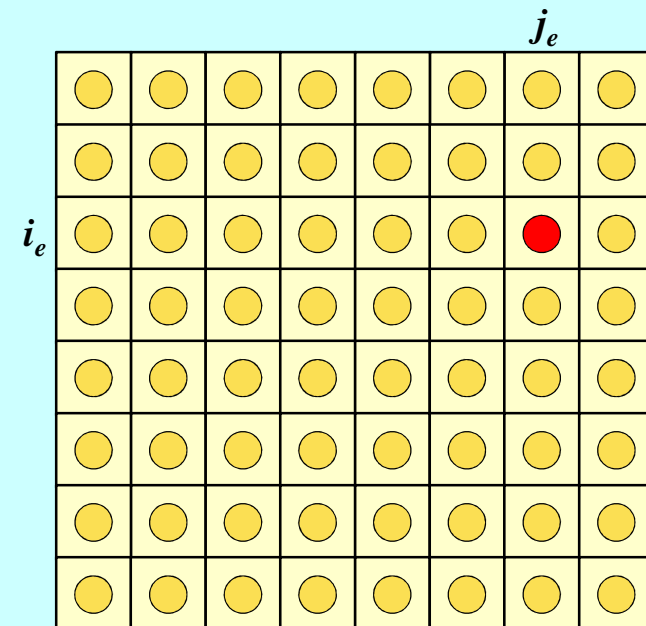

MAT_ASS_MAIN (1/6)

```
!C
!C***
!C*** MAT_ASS_MAIN
!C***
!C
subroutine MAT_ASS_MAIN
use pfem_util
implicit REAL*8 (A-H, O-Z)
integer(kind=kint), dimension( 8) :: nodLOCAL

allocate (AMAT(NPLU))
allocate (B(N), D(N), X(N))

AMAT= 0.d0
B= 0.d0
X= 0.d0
D= 0.d0

WEI (1)= +1. 0000000000D+00
WEI (2)= +1. 0000000000D+00

POS (1)= -0. 5773502692D+00
POS (2)= +0. 5773502692D+00

Non-Zero Off-Diagonal components (coef. matrix)
RHS vector
Unknowns
Diagonal components (coef. matrix)
```

MAT_ASS_MAIN (1/6)

```

!C
!C***
!C*** MAT_ASS_MAIN
!C***
!C
subroutine MAT_ASS_MAIN
use pfem_util
implicit REAL*8 (A-H, O-Z)
integer(kind=kint), dimension( 8) :: nodLOCAL

allocate (AMAT(NPLU))
allocate (B(N), D(N), X(N))

AMAT= 0. d0
B= 0. d0
X= 0. d0
D= 0. d0

WEI (1)= +1. 0000000000D+00
WEI (2)= +1. 0000000000D+00

POS (1)= -0. 5773502692D+00
POS (2)= +0. 5773502692D+00

```

POS: Quad. Point
WEI: Weighting Factor

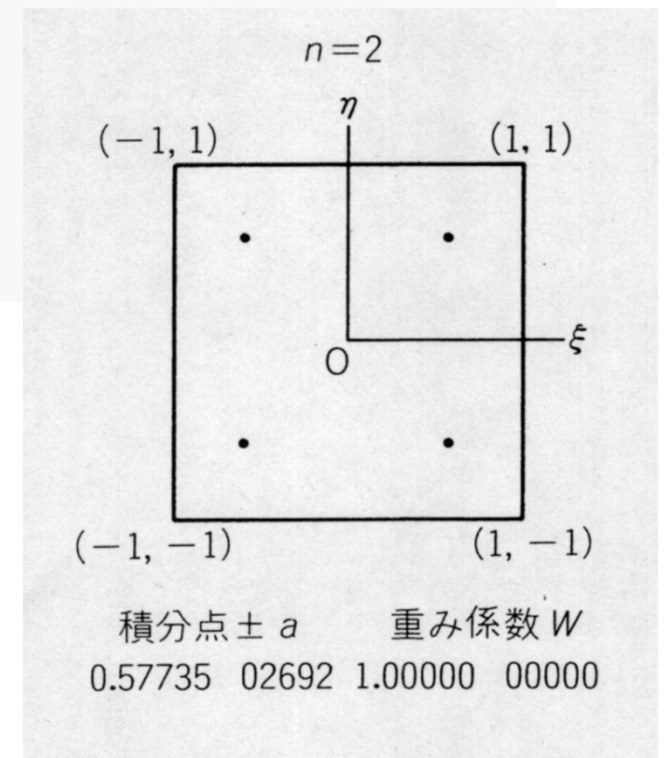

MAT_ASS_MAIN (2/6)

```
!C
!C-- INIT.
!C   PNQ   - 1st-order derivative of shape function by QSI
!C   PNE   - 1st-order derivative of shape function by ETA
!C   PNT   - 1st-order derivative of shape function by ZET
!C
```

```
do kp= 1, 2
do jp= 1, 2
do ip= 1, 2
```

```
QP1= 1. d0 + POS(ip)
QM1= 1. d0 - POS(ip)
EP1= 1. d0 + POS(jp)
EM1= 1. d0 - POS(jp)
TP1= 1. d0 + POS(kp)
TM1= 1. d0 - POS(kp)
```

```
SHAPE(ip, jp, kp, 1)= 08th * QM1 * EM1 * TM1
SHAPE(ip, jp, kp, 2)= 08th * QP1 * EM1 * TM1
SHAPE(ip, jp, kp, 3)= 08th * QP1 * EP1 * TM1
SHAPE(ip, jp, kp, 4)= 08th * QM1 * EP1 * TM1
SHAPE(ip, jp, kp, 5)= 08th * QM1 * EM1 * TP1
SHAPE(ip, jp, kp, 6)= 08th * QP1 * EM1 * TP1
SHAPE(ip, jp, kp, 7)= 08th * QP1 * EP1 * TP1
SHAPE(ip, jp, kp, 8)= 08th * QM1 * EP1 * TP1
```

MAT_ASS_MAIN (2/6)

```

!C
!C-- INIT.
!C   PNQ   - 1st-order derivative of shape function by QSI
!C   PNE   - 1st-order derivative of shape function by ETA
!C   PNT   - 1st-order derivative of shape function by ZET
!C

```

```

do kp= 1, 2
do jp= 1, 2
do ip= 1, 2

```

```

QP1= 1. d0 + POS(ip)
QM1= 1. d0 - POS(ip)
EP1= 1. d0 + POS(jp)
EM1= 1. d0 - POS(jp)
TP1= 1. d0 + POS(kp)
TM1= 1. d0 - POS(kp)

```

```

SHAPE(ip, jp, kp, 1) = 08th * QM1 * EM1 * TM1
SHAPE(ip, jp, kp, 2) = 08th * QP1 * EM1 * TM1
SHAPE(ip, jp, kp, 3) = 08th * QP1 * EP1 * TM1
SHAPE(ip, jp, kp, 4) = 08th * QM1 * EP1 * TM1
SHAPE(ip, jp, kp, 5) = 08th * QM1 * EM1 * TP1
SHAPE(ip, jp, kp, 6) = 08th * QP1 * EM1 * TP1
SHAPE(ip, jp, kp, 7) = 08th * QP1 * EP1 * TP1
SHAPE(ip, jp, kp, 8) = 08th * QM1 * EP1 * TP1

```

$$\begin{aligned}
 QP1(i) &= (1 + \xi_i), & QM1(i) &= (1 - \xi_i) \\
 EP1(j) &= (1 + \eta_j), & EM1(j) &= (1 - \eta_j) \\
 TP1(k) &= (1 + \zeta_k), & TM1(k) &= (1 - \zeta_k)
 \end{aligned}$$

MAT_ASS_MAIN (2/6)

```

!C
!C-- INIT.
!C   PNQ   - 1st-order derivative of shape function by QSI
!C   PNE   - 1st-order derivative of shape function by ETA
!C   PNT   - 1st-order derivative of shape function by ZET
!C

```

```

do kp= 1, 2
do jp= 1, 2
do ip= 1, 2

```

```

QP1= 1. d0 + POS(ip)
QM1= 1. d0 - POS(ip)
EP1= 1. d0 + POS(jp)
EM1= 1. d0 - POS(jp)
TP1= 1. d0 + POS(kp)
TM1= 1. d0 - POS(kp)

```

```

SHAPE(ip, jp, kp, 1) = 08th * QM1 * EM1 * TM1
SHAPE(ip, jp, kp, 2) = 08th * QP1 * EM1 * TM1
SHAPE(ip, jp, kp, 3) = 08th * QP1 * EP1 * TM1
SHAPE(ip, jp, kp, 4) = 08th * QM1 * EP1 * TM1
SHAPE(ip, jp, kp, 5) = 08th * QM1 * EM1 * TP1
SHAPE(ip, jp, kp, 6) = 08th * QP1 * EM1 * TP1
SHAPE(ip, jp, kp, 7) = 08th * QP1 * EP1 * TP1
SHAPE(ip, jp, kp, 8) = 08th * QM1 * EP1 * TP1

```

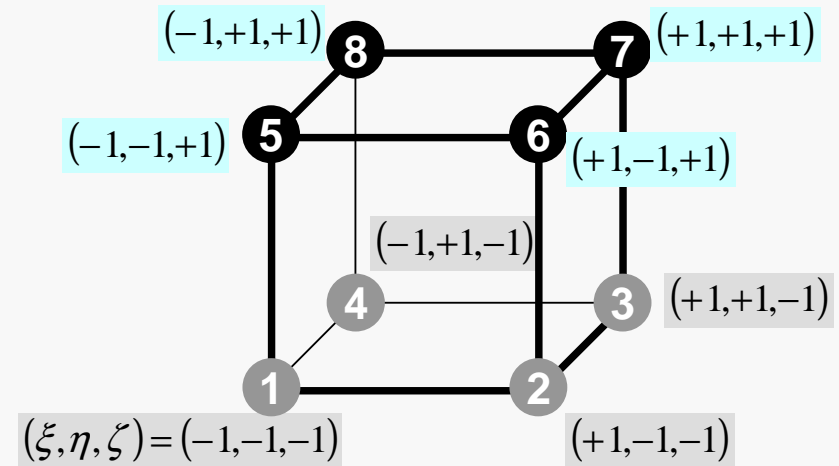

MAT_ASS_MAIN (2/6)

```

IC
IC-- INIT.
IC  PNQ  - 1st-order derivative of shape function by QSI
IC  PNE  - 1st-order derivative of shape function by ETA
IC  PNT  - 1st-order derivative of shape function by ZET
IC

```

```

do kp= 1, 2
do jp= 1, 2
do ip= 1, 2

```

```

QP1= 1. d0 + POS(ip)
QM1= 1. d0 - POS(ip)
EP1= 1. d0 + POS(jp)
EM1= 1. d0 - POS(jp)
TP1= 1. d0 + POS(kp)
TM1= 1. d0 - POS(kp)

```

```

SHAPE(ip, jp, kp, 1) = 08th * QM1 * EM1 * TM1
SHAPE(ip, jp, kp, 2) = 08th * QP1 * EM1 * TM1
SHAPE(ip, jp, kp, 3) = 08th * QP1 * EP1 * TM1
SHAPE(ip, jp, kp, 4) = 08th * QM1 * EP1 * TM1
SHAPE(ip, jp, kp, 5) = 08th * QM1 * EM1 * TP1
SHAPE(ip, jp, kp, 6) = 08th * QP1 * EM1 * TP1
SHAPE(ip, jp, kp, 7) = 08th * QP1 * EP1 * TP1
SHAPE(ip, jp, kp, 8) = 08th * QM1 * EP1 * TP1

```

$$N_1(\xi, \eta, \zeta) = \frac{1}{8}(1-\xi)(1-\eta)(1-\zeta)$$

$$N_2(\xi, \eta, \zeta) = \frac{1}{8}(1+\xi)(1-\eta)(1-\zeta)$$

$$N_3(\xi, \eta, \zeta) = \frac{1}{8}(1+\xi)(1+\eta)(1-\zeta)$$

$$N_4(\xi, \eta, \zeta) = \frac{1}{8}(1-\xi)(1+\eta)(1-\zeta)$$

$$N_5(\xi, \eta, \zeta) = \frac{1}{8}(1-\xi)(1-\eta)(1+\zeta)$$

$$N_6(\xi, \eta, \zeta) = \frac{1}{8}(1+\xi)(1-\eta)(1+\zeta)$$

$$N_7(\xi, \eta, \zeta) = \frac{1}{8}(1+\xi)(1+\eta)(1+\zeta)$$

$$N_8(\xi, \eta, \zeta) = \frac{1}{8}(1-\xi)(1+\eta)(1+\zeta)$$

MAT_ASS_MAIN (3/6)

```

PNQ (jp, kp, 1) = - 08th * EM1 * TM1
PNQ (jp, kp, 2) = + 08th * EM1 * TM1
PNQ (jp, kp, 3) = + 08th * EP1 * TM1
PNQ (jp, kp, 4) = - 08th * EP1 * TM1
PNQ (jp, kp, 5) = - 08th * EM1 * TP1
PNQ (jp, kp, 6) = + 08th * EM1 * TP1
PNQ (jp, kp, 7) = + 08th * EP1 * TP1
PNQ (jp, kp, 8) = - 08th * EP1 * TP1
PNE (ip, kp, 1) = - 08th * QM1 * TM1
PNE (ip, kp, 2) = - 08th * QP1 * TM1
PNE (ip, kp, 3) = + 08th * QP1 * TM1
PNE (ip, kp, 4) = + 08th * QM1 * TM1
PNE (ip, kp, 5) = - 08th * QM1 * TP1
PNE (ip, kp, 6) = - 08th * QP1 * TP1
PNE (ip, kp, 7) = + 08th * QP1 * TP1
PNE (ip, kp, 8) = + 08th * QM1 * TP1
PNT (ip, jp, 1) = - 08th * QM1 * EM1
PNT (ip, jp, 2) = - 08th * QP1 * EM1
PNT (ip, jp, 3) = - 08th * QP1 * EP1
PNT (ip, jp, 4) = - 08th * QM1 * EP1
PNT (ip, jp, 5) = + 08th * QM1 * EM1
PNT (ip, jp, 6) = + 08th * QP1 * EM1
PNT (ip, jp, 7) = + 08th * QP1 * EP1
PNT (ip, jp, 8) = + 08th * QM1 * EP1

```

```

enddo
enddo
enddo

```

```

do icel= 1, ICELTOT
  CONDO= COND

```

```

in1= ICELNOD (icel, 1)
in2= ICELNOD (icel, 2)
in3= ICELNOD (icel, 3)
in4= ICELNOD (icel, 4)
in5= ICELNOD (icel, 5)
in6= ICELNOD (icel, 6)
in7= ICELNOD (icel, 7)
in8= ICELNOD (icel, 8)

```

$$PNQ(j, k) = \frac{\partial N_l}{\partial \xi} (\xi = \xi_i, \eta = \eta_j, \zeta = \zeta_k)$$

$$PNE(i, k) = \frac{\partial N_l}{\partial \eta} (\xi = \xi_i, \eta = \eta_j, \zeta = \zeta_k)$$

$$PNT(i, j) = \frac{\partial N_l}{\partial \zeta} (\xi = \xi_i, \eta = \eta_j, \zeta = \zeta_k)$$

$$\frac{\partial N_1}{\partial \xi} (\xi_i, \eta_j, \zeta_k) = -\frac{1}{8} (1 - \eta_j)(1 - \zeta_k)$$

$$\frac{\partial N_2}{\partial \xi} (\xi_i, \eta_j, \zeta_k) = +\frac{1}{8} (1 - \eta_j)(1 - \zeta_k)$$

$$\frac{\partial N_3}{\partial \xi} (\xi_i, \eta_j, \zeta_k) = +\frac{1}{8} (1 + \eta_j)(1 - \zeta_k)$$

$$\frac{\partial N_3}{\partial \xi} (\xi_i, \eta_j, \zeta_k) = -\frac{1}{8} (1 + \eta_j)(1 - \zeta_k)$$

First Order Derivative
of Shape Functions at
 (ξ_i, η_j, ζ_k)

MAT_ASS_MAIN (3/6)

```

PNQ (jp, kp, 1) = - 08th * EM1 * TM1
PNQ (jp, kp, 2) = + 08th * EM1 * TM1
PNQ (jp, kp, 3) = + 08th * EP1 * TM1
PNQ (jp, kp, 4) = - 08th * EP1 * TM1
PNQ (jp, kp, 5) = - 08th * EM1 * TP1
PNQ (jp, kp, 6) = + 08th * EM1 * TP1
PNQ (jp, kp, 7) = + 08th * EP1 * TP1
PNQ (jp, kp, 8) = - 08th * EP1 * TP1
PNE (ip, kp, 1) = - 08th * QM1 * TM1
PNE (ip, kp, 2) = - 08th * QP1 * TM1
PNE (ip, kp, 3) = + 08th * QP1 * TM1
PNE (ip, kp, 4) = + 08th * QM1 * TM1
PNE (ip, kp, 5) = - 08th * QM1 * TP1
PNE (ip, kp, 6) = - 08th * QP1 * TP1
PNE (ip, kp, 7) = + 08th * QP1 * TP1
PNE (ip, kp, 8) = + 08th * QM1 * TP1
PNT (ip, jp, 1) = - 08th * QM1 * EM1
PNT (ip, jp, 2) = - 08th * QP1 * EM1
PNT (ip, jp, 3) = - 08th * QP1 * EP1
PNT (ip, jp, 4) = - 08th * QM1 * EP1
PNT (ip, jp, 5) = + 08th * QM1 * EM1
PNT (ip, jp, 6) = + 08th * QP1 * EM1
PNT (ip, jp, 7) = + 08th * QP1 * EP1
PNT (ip, jp, 8) = + 08th * QM1 * EP1

```

```

enddo
enddo
enddo

```

```

do icel= 1, ICELTOT
  CONDO= COND

```

```

in1= ICELNOD (icel, 1)
in2= ICELNOD (icel, 2)
in3= ICELNOD (icel, 3)
in4= ICELNOD (icel, 4)
in5= ICELNOD (icel, 5)
in6= ICELNOD (icel, 6)
in7= ICELNOD (icel, 7)
in8= ICELNOD (icel, 8)

```

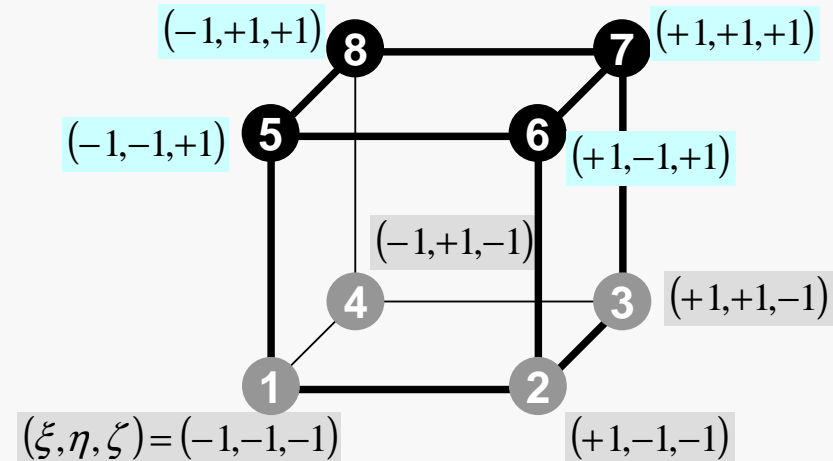

MAT_ASS_MAIN (4/6)

```

nodLOCAL (1) = in1
nodLOCAL (2) = in2
nodLOCAL (3) = in3
nodLOCAL (4) = in4
nodLOCAL (5) = in5
nodLOCAL (6) = in6
nodLOCAL (7) = in7
nodLOCAL (8) = in8

```

Node ID (Global)

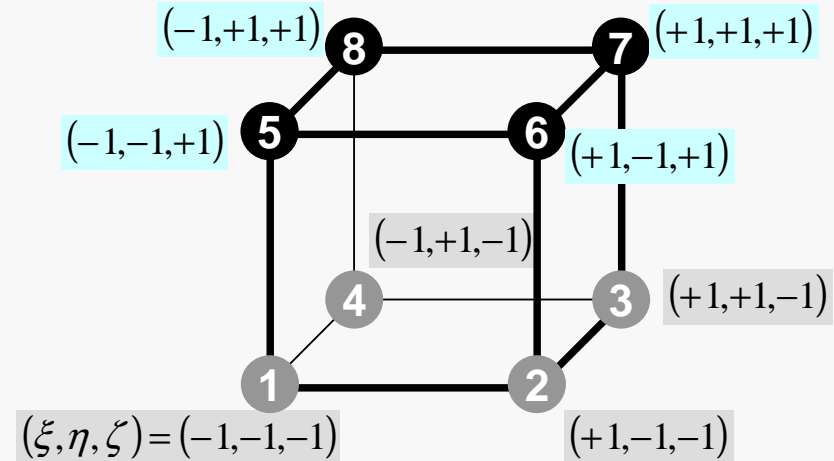

```

X1= XYZ (in1, 1)
X2= XYZ (in2, 1)
X3= XYZ (in3, 1)
X4= XYZ (in4, 1)
X5= XYZ (in5, 1)
X6= XYZ (in6, 1)
X7= XYZ (in7, 1)
X8= XYZ (in8, 1)
Y1= XYZ (in1, 2)
Y2= XYZ (in2, 2)
Y3= XYZ (in3, 2)
Y4= XYZ (in4, 2)
Y5= XYZ (in5, 2)
Y6= XYZ (in6, 2)
Y7= XYZ (in7, 2)
Y8= XYZ (in8, 2)
QVC= 08th * (X1+X2+X3+X4+X5+X6+X7+X8+
& Y1+Y2+Y3+Y4+Y5+Y6+Y7+Y8)

```

```

Z1= XYZ (in1, 3)
Z2= XYZ (in2, 3)
Z3= XYZ (in3, 3)
Z4= XYZ (in4, 3)
Z5= XYZ (in5, 3)
Z6= XYZ (in6, 3)
Z7= XYZ (in7, 3)
Z8= XYZ (in8, 3)

```

```

call JACOBI (DETJ, PNQ, PNE, PNT, PNQ, PNY, PNZ,
& X1, X2, X3, X4, X5, X6, X7, X8,
& Y1, Y2, Y3, Y4, Y5, Y6, Y7, Y8,
& Z1, Z2, Z3, Z4, Z5, Z6, Z7, Z8 )

```

MAT_ASS_MAIN (4/6)

```

nodLOCAL (1) = in1
nodLOCAL (2) = in2
nodLOCAL (3) = in3
nodLOCAL (4) = in4
nodLOCAL (5) = in5
nodLOCAL (6) = in6
nodLOCAL (7) = in7
nodLOCAL (8) = in8

```

```

X1= XYZ (in1, 1)
X2= XYZ (in2, 1)
X3= XYZ (in3, 1)
X4= XYZ (in4, 1)
X5= XYZ (in5, 1)
X6= XYZ (in6, 1)
X7= XYZ (in7, 1)
X8= XYZ (in8, 1)

```

X-Coordinates
of 8 nodes

```

Y1= XYZ (in1, 2)
Y2= XYZ (in2, 2)
Y3= XYZ (in3, 2)
Y4= XYZ (in4, 2)
Y5= XYZ (in5, 2)
Y6= XYZ (in6, 2)
Y7= XYZ (in7, 2)
Y8= XYZ (in8, 2)

```

Y-Coordinates
of 8 nodes

```

QVC= 08th * (X1+X2+X3+X4+X5+X6+X7+X8+
             Y1+Y2+Y3+Y4+Y5+Y6+Y7+Y8)

```

&

```

Z1= XYZ (in1, 3)
Z2= XYZ (in2, 3)
Z3= XYZ (in3, 3)
Z4= XYZ (in4, 3)
Z5= XYZ (in5, 3)
Z6= XYZ (in6, 3)
Z7= XYZ (in7, 3)
Z8= XYZ (in8, 3)

```

Z-Coordinates
of 8 nodes

```

call JACOBI (DETJ, PNQ, PNE, PNT, PNx, PNY, PNz,
             X1, X2, X3, X4, X5, X6, X7, X8,
             Y1, Y2, Y3, Y4, Y5, Y6, Y7, Y8,
             Z1, Z2, Z3, Z4, Z5, Z6, Z7, Z8 )

```

&
&
&

&
&
&

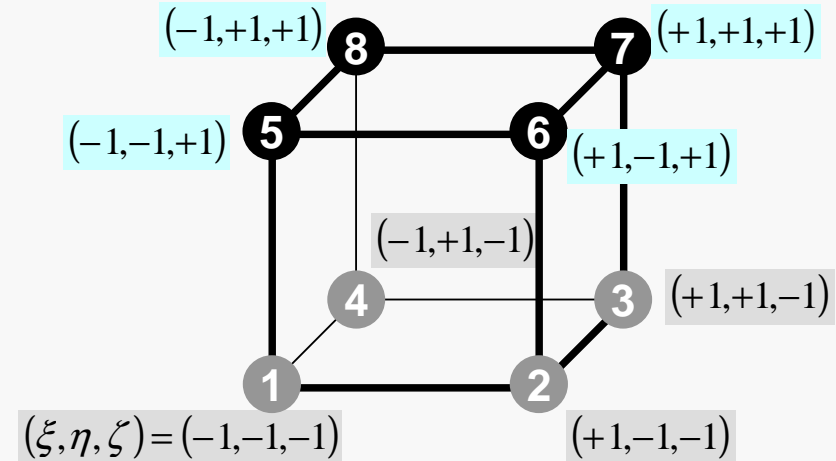

MAT_ASS_MAIN (4/6)

```

nodLOCAL (1) = in1
nodLOCAL (2) = in2
nodLOCAL (3) = in3
nodLOCAL (4) = in4
nodLOCAL (5) = in5
nodLOCAL (6) = in6
nodLOCAL (7) = in7
nodLOCAL (8) = in8

```

```

X1= XYZ (in1, 1)
X2= XYZ (in2, 1)
X3= XYZ (in3, 1)
X4= XYZ (in4, 1)
X5= XYZ (in5, 1)
X6= XYZ (in6, 1)
X7= XYZ (in7, 1)
X8= XYZ (in8, 1)
Y1= XYZ (in1, 2)
Y2= XYZ (in2, 2)
Y3= XYZ (in3, 2)
Y4= XYZ (in4, 2)
Y5= XYZ (in5, 2)
Y6= XYZ (in6, 2)
Y7= XYZ (in7, 2)
Y8= XYZ (in8, 2)

```

X-Coordinates
of 8 nodes

Y-Coordinates
of 8 nodes

```

& QVC= 08th * (X1+X2+X3+X4+X5+X6+X7+X8+
              Y1+Y2+Y3+Y4+Y5+Y6+Y7+Y8)

```

```

Z1= XYZ (in1, 3)
Z2= XYZ (in2, 3)
Z3= XYZ (in3, 3)
Z4= XYZ (in4, 3)
Z5= XYZ (in5, 3)
Z6= XYZ (in6, 3)
Z7= XYZ (in7, 3)
Z8= XYZ (in8, 3)

```

```

& call JACOBI (DETJ, PNQ, PNE, PNT, PNx, PNY, PNz,
&              X1, X2, X3, X4, X5, X6, X7, X8,
&              Y1, Y2, Y3, Y4, Y5, Y6, Y7, Y8,
&              Z1, Z2, Z3, Z4, Z5, Z6, Z7, Z8 )

```

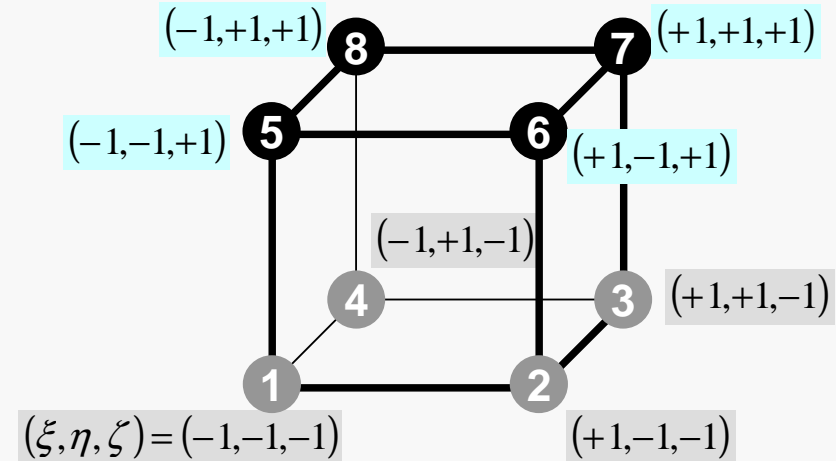

$$\frac{\partial}{\partial x} \left(\lambda \frac{\partial T}{\partial x} \right) + \frac{\partial}{\partial y} \left(\lambda \frac{\partial T}{\partial y} \right) + \frac{\partial}{\partial z} \left(\lambda \frac{\partial T}{\partial z} \right) + \dot{Q}(x, y, z) = 0$$

$$\dot{Q}(x, y, z) = QVOL |x_c + y_c|$$

Heat Gen. Rate is a function of location
(cell center: x_c, y_c)

MAT_ASS_MAIN (4/6)

```

nodLOCAL (1) = in1
nodLOCAL (2) = in2
nodLOCAL (3) = in3
nodLOCAL (4) = in4
nodLOCAL (5) = in5
nodLOCAL (6) = in6
nodLOCAL (7) = in7
nodLOCAL (8) = in8

```

```

X1= XYZ (in1, 1)
X2= XYZ (in2, 1)
X3= XYZ (in3, 1)
X4= XYZ (in4, 1)
X5= XYZ (in5, 1)
X6= XYZ (in6, 1)
X7= XYZ (in7, 1)
X8= XYZ (in8, 1)
Y1= XYZ (in1, 2)
Y2= XYZ (in2, 2)
Y3= XYZ (in3, 2)
Y4= XYZ (in4, 2)
Y5= XYZ (in5, 2)
Y6= XYZ (in6, 2)
Y7= XYZ (in7, 2)
Y8= XYZ (in8, 2)

```

```

& QVC= 08th * (X1+X2+X3+X4+X5+X6+X7+X8+
Y1+Y2+Y3+Y4+Y5+Y6+Y7+Y8)

```

```

Z1= XYZ (in1, 3)
Z2= XYZ (in2, 3)
Z3= XYZ (in3, 3)
Z4= XYZ (in4, 3)
Z5= XYZ (in5, 3)
Z6= XYZ (in6, 3)
Z7= XYZ (in7, 3)
Z8= XYZ (in8, 3)

```

```

call JACOBI (DETJ, PNQ, PNE, PNT, PNx, PNY, PNz,
& X1, X2, X3, X4, X5, X6, X7, X8,
& Y1, Y2, Y3, Y4, Y5, Y6, Y7, Y8,
& Z1, Z2, Z3, Z4, Z5, Z6, Z7, Z8 )

```

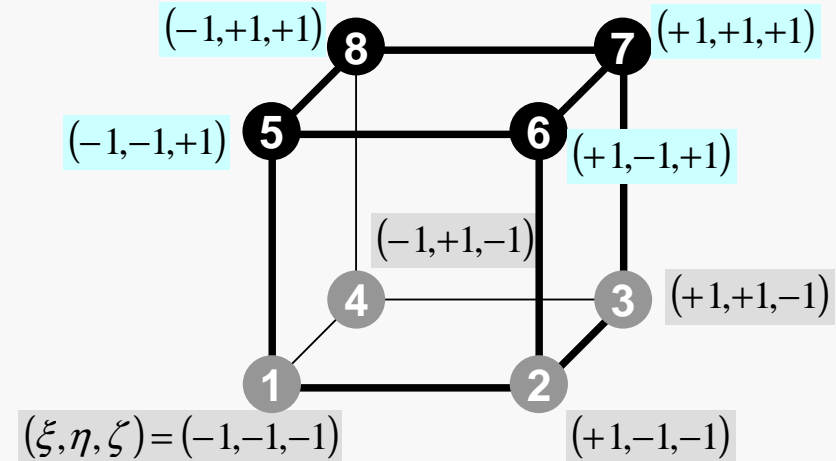

$$\frac{\partial}{\partial x} \left(\lambda \frac{\partial T}{\partial x} \right) + \frac{\partial}{\partial y} \left(\lambda \frac{\partial T}{\partial y} \right) + \frac{\partial}{\partial z} \left(\lambda \frac{\partial T}{\partial z} \right) + \dot{Q}(x, y, z) = 0$$

$$\dot{Q}(x, y, z) = QVOL |x_c + y_c|$$

$$QVC = |x_c + y_c|$$

MAT_ASS_MAIN (4/6)

```

nodLOCAL (1) = in1
nodLOCAL (2) = in2
nodLOCAL (3) = in3
nodLOCAL (4) = in4
nodLOCAL (5) = in5
nodLOCAL (6) = in6
nodLOCAL (7) = in7
nodLOCAL (8) = in8

```

```

X1= XYZ (in1, 1)
X2= XYZ (in2, 1)
X3= XYZ (in3, 1)
X4= XYZ (in4, 1)
X5= XYZ (in5, 1)
X6= XYZ (in6, 1)
X7= XYZ (in7, 1)
X8= XYZ (in8, 1)
Y1= XYZ (in1, 2)
Y2= XYZ (in2, 2)
Y3= XYZ (in3, 2)
Y4= XYZ (in4, 2)
Y5= XYZ (in5, 2)
Y6= XYZ (in6, 2)
Y7= XYZ (in7, 2)
Y8= XYZ (in8, 2)

```

```

QVC= 08th * (X1+X2+X3+X4+X5+X6+X7+X8+
& Y1+Y2+Y3+Y4+Y5+Y6+Y7+Y8)

```

```

Z1= XYZ (in1, 3)
Z2= XYZ (in2, 3)
Z3= XYZ (in3, 3)
Z4= XYZ (in4, 3)
Z5= XYZ (in5, 3)
Z6= XYZ (in6, 3)
Z7= XYZ (in7, 3)
Z8= XYZ (in8, 3)

```

```

call JACOBI (DETJ, PNQ, PNE, PNT, PNQ, PNY, PNZ,
& X1, X2, X3, X4, X5, X6, X7, X8,
& Y1, Y2, Y3, Y4, Y5, Y6, Y7, Y8,
& Z1, Z2, Z3, Z4, Z5, Z6, Z7, Z8 )

```

```

&
&
&

```

JACOBI (1/4)

```
subroutine JACOBI (DETJ, PNQ, PNE, PNT, PNQ, PNY, PNZ,
& X1, X2, X3, X4, X5, X6, X7, X8, Y1, Y2, Y3, Y4, Y5, Y6, Y7, Y8, &
& Z1, Z2, Z3, Z4, Z5, Z6, Z7, Z8 )
```

```
!C
!C
!C
!C
```

```
calculates JACOBIAN & INVERSE JACOBIAN
dNi/dx, dNi/dy & dNi/dz
```

```
implicit REAL*8 (A-H, O-Z)
dimension DETJ(2, 2, 2)
dimension PNQ(2, 2, 8), PNE(2, 2, 8), PNT(2, 2, 8)
dimension PNQ(2, 2, 2, 8), PNY(2, 2, 2, 8), PNZ(2, 2, 2, 8)
```

```
do kp= 1, 2
do jp= 1, 2
do ip= 1, 2
PNX(ip, jp, kp, 1)=0. d0
PNX(ip, jp, kp, 2)=0. d0
PNX(ip, jp, kp, 3)=0. d0
PNX(ip, jp, kp, 4)=0. d0
PNX(ip, jp, kp, 5)=0. d0
PNX(ip, jp, kp, 6)=0. d0
PNX(ip, jp, kp, 7)=0. d0
PNX(ip, jp, kp, 8)=0. d0
PNY(ip, jp, kp, 1)=0. d0
PNY(ip, jp, kp, 2)=0. d0
PNY(ip, jp, kp, 3)=0. d0
PNY(ip, jp, kp, 4)=0. d0
PNY(ip, jp, kp, 5)=0. d0
PNY(ip, jp, kp, 6)=0. d0
PNY(ip, jp, kp, 7)=0. d0
PNY(ip, jp, kp, 8)=0. d0
PNZ(ip, jp, kp, 1)=0. d0
PNZ(ip, jp, kp, 2)=0. d0
PNZ(ip, jp, kp, 3)=0. d0
PNZ(ip, jp, kp, 4)=0. d0
PNZ(ip, jp, kp, 5)=0. d0
PNZ(ip, jp, kp, 6)=0. d0
PNZ(ip, jp, kp, 7)=0. d0
PNZ(ip, jp, kp, 8)=0. d0
```

Input

$$\left[\frac{\partial N_l}{\partial \xi}, \frac{\partial N_l}{\partial \eta}, \frac{\partial N_l}{\partial \zeta} \right], (x_l, y_l, z_l) (l = 1 \sim 8)$$

Output

$$\left[\frac{\partial N_l}{\partial x}, \frac{\partial N_l}{\partial y}, \frac{\partial N_l}{\partial z} \right], \det|J|$$

**Values at each Gaussian Quad.
Points: (ip,jp,kp)**

Partial Diff. on Natural Coord. (1/4)

- According to formulae:

$$\frac{\partial N_i(\xi, \eta, \zeta)}{\partial \xi} = \frac{\partial N_i}{\partial x} \frac{\partial x}{\partial \xi} + \frac{\partial N_i}{\partial y} \frac{\partial y}{\partial \xi} + \frac{\partial N_i}{\partial z} \frac{\partial z}{\partial \xi}$$

$$\frac{\partial N_i(\xi, \eta, \zeta)}{\partial \eta} = \frac{\partial N_i}{\partial x} \frac{\partial x}{\partial \eta} + \frac{\partial N_i}{\partial y} \frac{\partial y}{\partial \eta} + \frac{\partial N_i}{\partial z} \frac{\partial z}{\partial \eta}$$

$$\frac{\partial N_i(\xi, \eta, \zeta)}{\partial \zeta} = \frac{\partial N_i}{\partial x} \frac{\partial x}{\partial \zeta} + \frac{\partial N_i}{\partial y} \frac{\partial y}{\partial \zeta} + \frac{\partial N_i}{\partial z} \frac{\partial z}{\partial \zeta}$$

$\left[\frac{\partial N_i}{\partial \xi}, \frac{\partial N_i}{\partial \eta}, \frac{\partial N_i}{\partial \zeta} \right]$ can be easily derived according to definitions.

$\left[\frac{\partial N_i}{\partial x}, \frac{\partial N_i}{\partial y}, \frac{\partial N_i}{\partial z} \right]$ are required for computations.

Partial Diff. on Natural Coord. (2/4)

- In matrix form:

$$\begin{Bmatrix} \frac{\partial N_i}{\partial \xi} \\ \frac{\partial N_i}{\partial \eta} \\ \frac{\partial N_i}{\partial \zeta} \end{Bmatrix} = \begin{bmatrix} \frac{\partial x}{\partial \xi} & \frac{\partial y}{\partial \xi} & \frac{\partial z}{\partial \xi} \\ \frac{\partial x}{\partial \eta} & \frac{\partial y}{\partial \eta} & \frac{\partial z}{\partial \eta} \\ \frac{\partial x}{\partial \zeta} & \frac{\partial y}{\partial \zeta} & \frac{\partial z}{\partial \zeta} \end{bmatrix} \begin{Bmatrix} \frac{\partial N_i}{\partial x} \\ \frac{\partial N_i}{\partial y} \\ \frac{\partial N_i}{\partial z} \end{Bmatrix} = [J] \begin{Bmatrix} \frac{\partial N_i}{\partial x} \\ \frac{\partial N_i}{\partial y} \\ \frac{\partial N_i}{\partial z} \end{Bmatrix}$$

$$[J] = \begin{bmatrix} J_{11} & J_{12} & J_{13} \\ J_{21} & J_{22} & J_{23} \\ J_{31} & J_{32} & J_{33} \end{bmatrix}$$

$[J]$: Jacobi matrix, Jacobian

Partial Diff. on Natural Coord. (3/4)

- Components of Jacobian:

$$J_{11} = \frac{\partial x}{\partial \xi} = \frac{\partial}{\partial \xi} \left(\sum_{i=1}^8 N_i x_i \right) = \sum_{i=1}^8 \frac{\partial N_i}{\partial \xi} x_i, \quad J_{12} = \frac{\partial y}{\partial \xi} = \frac{\partial}{\partial \xi} \left(\sum_{i=1}^8 N_i y_i \right) = \sum_{i=1}^8 \frac{\partial N_i}{\partial \xi} y_i,$$

$$J_{13} = \frac{\partial z}{\partial \xi} = \frac{\partial}{\partial \xi} \left(\sum_{i=1}^8 N_i z_i \right) = \sum_{i=1}^8 \frac{\partial N_i}{\partial \xi} z_i$$

$$J_{21} = \frac{\partial x}{\partial \eta} = \frac{\partial}{\partial \eta} \left(\sum_{i=1}^8 N_i x_i \right) = \sum_{i=1}^8 \frac{\partial N_i}{\partial \eta} x_i, \quad J_{22} = \frac{\partial y}{\partial \eta} = \frac{\partial}{\partial \eta} \left(\sum_{i=1}^8 N_i y_i \right) = \sum_{i=1}^8 \frac{\partial N_i}{\partial \eta} y_i,$$

$$J_{23} = \frac{\partial z}{\partial \eta} = \frac{\partial}{\partial \eta} \left(\sum_{i=1}^8 N_i z_i \right) = \sum_{i=1}^8 \frac{\partial N_i}{\partial \eta} z_i$$

$$J_{31} = \frac{\partial x}{\partial \zeta} = \frac{\partial}{\partial \zeta} \left(\sum_{i=1}^8 N_i x_i \right) = \sum_{i=1}^8 \frac{\partial N_i}{\partial \zeta} x_i, \quad J_{32} = \frac{\partial y}{\partial \zeta} = \frac{\partial}{\partial \zeta} \left(\sum_{i=1}^8 N_i y_i \right) = \sum_{i=1}^8 \frac{\partial N_i}{\partial \zeta} y_i,$$

$$J_{33} = \frac{\partial z}{\partial \zeta} = \frac{\partial}{\partial \zeta} \left(\sum_{i=1}^8 N_i z_i \right) = \sum_{i=1}^8 \frac{\partial N_i}{\partial \zeta} z_i$$

JACOBI (2/4)

!C
!C== DETERMINANT of the JACOBIAN

$$\begin{aligned}
 dXdQ &= + \text{PNQ}(\text{jp}, \text{kp}, 1) * X1 + \text{PNQ}(\text{jp}, \text{kp}, 2) * X2 \\
 &+ \text{PNQ}(\text{jp}, \text{kp}, 3) * X3 + \text{PNQ}(\text{jp}, \text{kp}, 4) * X4 \\
 &+ \text{PNQ}(\text{jp}, \text{kp}, 5) * X5 + \text{PNQ}(\text{jp}, \text{kp}, 6) * X6 \\
 &+ \text{PNQ}(\text{jp}, \text{kp}, 7) * X7 + \text{PNQ}(\text{jp}, \text{kp}, 8) * X8 \\
 dYdQ &= + \text{PNQ}(\text{jp}, \text{kp}, 1) * Y1 + \text{PNQ}(\text{jp}, \text{kp}, 2) * Y2 \\
 &+ \text{PNQ}(\text{jp}, \text{kp}, 3) * Y3 + \text{PNQ}(\text{jp}, \text{kp}, 4) * Y4 \\
 &+ \text{PNQ}(\text{jp}, \text{kp}, 5) * Y5 + \text{PNQ}(\text{jp}, \text{kp}, 6) * Y6 \\
 &+ \text{PNQ}(\text{jp}, \text{kp}, 7) * Y7 + \text{PNQ}(\text{jp}, \text{kp}, 8) * Y8 \\
 dZdQ &= + \text{PNQ}(\text{jp}, \text{kp}, 1) * Z1 + \text{PNQ}(\text{jp}, \text{kp}, 2) * Z2 \\
 &+ \text{PNQ}(\text{jp}, \text{kp}, 3) * Z3 + \text{PNQ}(\text{jp}, \text{kp}, 4) * Z4 \\
 &+ \text{PNQ}(\text{jp}, \text{kp}, 5) * Z5 + \text{PNQ}(\text{jp}, \text{kp}, 6) * Z6 \\
 &+ \text{PNQ}(\text{jp}, \text{kp}, 7) * Z7 + \text{PNQ}(\text{jp}, \text{kp}, 8) * Z8 \\
 dXdE &= + \text{PNE}(\text{ip}, \text{kp}, 1) * X1 + \text{PNE}(\text{ip}, \text{kp}, 2) * X2 \\
 &+ \text{PNE}(\text{ip}, \text{kp}, 3) * X3 + \text{PNE}(\text{ip}, \text{kp}, 4) * X4 \\
 &+ \text{PNE}(\text{ip}, \text{kp}, 5) * X5 + \text{PNE}(\text{ip}, \text{kp}, 6) * X6 \\
 &+ \text{PNE}(\text{ip}, \text{kp}, 7) * X7 + \text{PNE}(\text{ip}, \text{kp}, 8) * X8 \\
 dYdE &= + \text{PNE}(\text{ip}, \text{kp}, 1) * Y1 + \text{PNE}(\text{ip}, \text{kp}, 2) * Y2 \\
 &+ \text{PNE}(\text{ip}, \text{kp}, 3) * Y3 + \text{PNE}(\text{ip}, \text{kp}, 4) * Y4 \\
 &+ \text{PNE}(\text{ip}, \text{kp}, 5) * Y5 + \text{PNE}(\text{ip}, \text{kp}, 6) * Y6 \\
 &+ \text{PNE}(\text{ip}, \text{kp}, 7) * Y7 + \text{PNE}(\text{ip}, \text{kp}, 8) * Y8 \\
 dZdE &= + \text{PNE}(\text{ip}, \text{kp}, 1) * Z1 + \text{PNE}(\text{ip}, \text{kp}, 2) * Z2 \\
 &+ \text{PNE}(\text{ip}, \text{kp}, 3) * Z3 + \text{PNE}(\text{ip}, \text{kp}, 4) * Z4 \\
 &+ \text{PNE}(\text{ip}, \text{kp}, 5) * Z5 + \text{PNE}(\text{ip}, \text{kp}, 6) * Z6 \\
 &+ \text{PNE}(\text{ip}, \text{kp}, 7) * Z7 + \text{PNE}(\text{ip}, \text{kp}, 8) * Z8
 \end{aligned}$$

$$[J] = \begin{bmatrix} J_{11} & J_{12} & J_{13} \\ J_{21} & J_{22} & J_{23} \\ J_{31} & J_{32} & J_{33} \end{bmatrix}$$

$$\begin{aligned}
 dXdQ &= \frac{\partial x}{\partial \xi} = J_{11} \\
 dYdQ &= \frac{\partial y}{\partial \xi} = J_{12} \\
 dZdQ &= \frac{\partial z}{\partial \xi} = J_{13}
 \end{aligned}$$

JACOBI (3/4)

```

&      dXdT =
&      + PNT(ip, jp, 1) * X1 + PNT(ip, jp, 2) * X2
&      + PNT(ip, jp, 3) * X3 + PNT(ip, jp, 4) * X4
&      + PNT(ip, jp, 5) * X5 + PNT(ip, jp, 6) * X6
&      + PNT(ip, jp, 7) * X7 + PNT(ip, jp, 8) * X8
&
&      dYdT =
&      + PNT(ip, jp, 1) * Y1 + PNT(ip, jp, 2) * Y2
&      + PNT(ip, jp, 3) * Y3 + PNT(ip, jp, 4) * Y4
&      + PNT(ip, jp, 5) * Y5 + PNT(ip, jp, 6) * Y6
&      + PNT(ip, jp, 7) * Y7 + PNT(ip, jp, 8) * Y8
&
&      dZdT =
&      + PNT(ip, jp, 1) * Z1 + PNT(ip, jp, 2) * Z2
&      + PNT(ip, jp, 3) * Z3 + PNT(ip, jp, 4) * Z4
&      + PNT(ip, jp, 5) * Z5 + PNT(ip, jp, 6) * Z6
&      + PNT(ip, jp, 7) * Z7 + PNT(ip, jp, 8) * Z8
&
&      DETJ(ip, jp, kp) = dXdQ*(dYdE*dZdT-dZdE*dYdT) +
&      dYdQ*(dZdE*dXdT-dXdE*dZdT) +
&      dZdQ*(dXdE*dYdT-dYdE*dXdT)

```

```

!C
!C== INVERSE JACOBIAN
coef= 1. d0 / DETJ(ip, jp, kp)

```

```

a11= coef * ( dYdE*dZdT - dZdE*dYdT )
a12= coef * ( dZdQ*dYdT - dYdQ*dZdT )
a13= coef * ( dYdQ*dZdE - dZdQ*dYdE )

```

```

a21= coef * ( dZdE*dXdT - dXdE*dZdT )
a22= coef * ( dXdQ*dZdT - dZdQ*dXdT )
a23= coef * ( dZdQ*dXdE - dXdQ*dZdE )

```

```

a31= coef * ( dXdE*dYdT - dYdE*dXdT )
a32= coef * ( dYdQ*dXdT - dXdQ*dYdT )
a33= coef * ( dXdQ*dYdE - dYdQ*dXdE )

```

```

DETJ(ip, jp, kp) = dabs(DETJ(ip, jp, kp))

```

$$[J] = \begin{bmatrix} J_{11} & J_{12} & J_{13} \\ J_{21} & J_{22} & J_{23} \\ J_{31} & J_{32} & J_{33} \end{bmatrix}$$

Partial Diff. on Natural Coord. (4/4)

- Partial differentiation on global coordinate system is introduced as follows (with inverse of Jacobian matrix (3×3))

$$\begin{Bmatrix} \frac{\partial N_i}{\partial x} \\ \frac{\partial N_i}{\partial y} \\ \frac{\partial N_i}{\partial z} \end{Bmatrix} = \begin{bmatrix} \frac{\partial x}{\partial \xi} & \frac{\partial y}{\partial \xi} & \frac{\partial z}{\partial \xi} \\ \frac{\partial x}{\partial \eta} & \frac{\partial y}{\partial \eta} & \frac{\partial z}{\partial \eta} \\ \frac{\partial x}{\partial \zeta} & \frac{\partial y}{\partial \zeta} & \frac{\partial z}{\partial \zeta} \end{bmatrix}^{-1} \begin{Bmatrix} \frac{\partial N_i}{\partial \xi} \\ \frac{\partial N_i}{\partial \eta} \\ \frac{\partial N_i}{\partial \zeta} \end{Bmatrix} = [J]^{-1} \begin{Bmatrix} \frac{\partial N_i}{\partial \xi} \\ \frac{\partial N_i}{\partial \eta} \\ \frac{\partial N_i}{\partial \zeta} \end{Bmatrix}$$

JACOBI (3/4)

```

dXdT =
& + PNT(ip, jp, 1) * X1 + PNT(ip, jp, 2) * X2 &
& + PNT(ip, jp, 3) * X3 + PNT(ip, jp, 4) * X4 &
& + PNT(ip, jp, 5) * X5 + PNT(ip, jp, 6) * X6 &
& + PNT(ip, jp, 7) * X7 + PNT(ip, jp, 8) * X8

dYdT =
& + PNT(ip, jp, 1) * Y1 + PNT(ip, jp, 2) * Y2 &
& + PNT(ip, jp, 3) * Y3 + PNT(ip, jp, 4) * Y4 &
& + PNT(ip, jp, 5) * Y5 + PNT(ip, jp, 6) * Y6 &
& + PNT(ip, jp, 7) * Y7 + PNT(ip, jp, 8) * Y8

dZdT =
& + PNT(ip, jp, 1) * Z1 + PNT(ip, jp, 2) * Z2 &
& + PNT(ip, jp, 3) * Z3 + PNT(ip, jp, 4) * Z4 &
& + PNT(ip, jp, 5) * Z5 + PNT(ip, jp, 6) * Z6 &
& + PNT(ip, jp, 7) * Z7 + PNT(ip, jp, 8) * Z8

DETJ(ip, jp, kp) = dXdQ*(dYdE*dZdT-dZdE*dYdT) +
& dYdQ*(dZdE*dXdT-dXdE*dZdT) + &
& dZdQ*(dXdE*dYdT-dYdE*dXdT)

!C
!C== INVERSE JACOBIAN
coef= 1. d0 / DETJ(ip, jp, kp)

a11= coef * ( dYdE*dZdT - dZdE*dYdT )
a12= coef * ( dZdQ*dYdT - dYdQ*dZdT )
a13= coef * ( dYdQ*dZdE - dZdQ*dYdE )

a21= coef * ( dZdE*dXdT - dXdE*dZdT )
a22= coef * ( dXdQ*dZdT - dZdQ*dXdT )
a23= coef * ( dZdQ*dXdE - dXdQ*dZdE )

a31= coef * ( dXdE*dYdT - dYdE*dXdT )
a32= coef * ( dYdQ*dXdT - dXdQ*dYdT )
a33= coef * ( dXdQ*dYdE - dYdQ*dXdE )

DETJ(ip, jp, kp) = dabs(DETJ(ip, jp, kp))

```

$$[J]^{-1} = \begin{bmatrix} a_{11} & a_{12} & a_{13} \\ a_{21} & a_{22} & a_{23} \\ a_{31} & a_{32} & a_{33} \end{bmatrix}$$

JACOBI (4/4)

!C

!C== set the dNi/dX, dNi/dY & dNi/dZ components

```

PNX (ip, jp, kp, 1) = a11*PNQ (jp, kp, 1) + a12*PNE (ip, kp, 1) + a13*PNT (ip, jp, 1)
PNX (ip, jp, kp, 2) = a11*PNQ (jp, kp, 2) + a12*PNE (ip, kp, 2) + a13*PNT (ip, jp, 2)
PNX (ip, jp, kp, 3) = a11*PNQ (jp, kp, 3) + a12*PNE (ip, kp, 3) + a13*PNT (ip, jp, 3)
PNX (ip, jp, kp, 4) = a11*PNQ (jp, kp, 4) + a12*PNE (ip, kp, 4) + a13*PNT (ip, jp, 4)
PNX (ip, jp, kp, 5) = a11*PNQ (jp, kp, 5) + a12*PNE (ip, kp, 5) + a13*PNT (ip, jp, 5)
PNX (ip, jp, kp, 6) = a11*PNQ (jp, kp, 6) + a12*PNE (ip, kp, 6) + a13*PNT (ip, jp, 6)
PNX (ip, jp, kp, 7) = a11*PNQ (jp, kp, 7) + a12*PNE (ip, kp, 7) + a13*PNT (ip, jp, 7)
PNX (ip, jp, kp, 8) = a11*PNQ (jp, kp, 8) + a12*PNE (ip, kp, 8) + a13*PNT (ip, jp, 8)

```

```

PNY (ip, jp, kp, 1) = a21*PNQ (jp, kp, 1) + a22*PNE (ip, kp, 1) + a23*PNT (ip, jp, 1)
PNY (ip, jp, kp, 2) = a21*PNQ (jp, kp, 2) + a22*PNE (ip, kp, 2) + a23*PNT (ip, jp, 2)
PNY (ip, jp, kp, 3) = a21*PNQ (jp, kp, 3) + a22*PNE (ip, kp, 3) + a23*PNT (ip, jp, 3)
PNY (ip, jp, kp, 4) = a21*PNQ (jp, kp, 4) + a22*PNE (ip, kp, 4) + a23*PNT (ip, jp, 4)
PNY (ip, jp, kp, 5) = a21*PNQ (jp, kp, 5) + a22*PNE (ip, kp, 5) + a23*PNT (ip, jp, 5)
PNY (ip, jp, kp, 6) = a21*PNQ (jp, kp, 6) + a22*PNE (ip, kp, 6) + a23*PNT (ip, jp, 6)
PNY (ip, jp, kp, 7) = a21*PNQ (jp, kp, 7) + a22*PNE (ip, kp, 7) + a23*PNT (ip, jp, 7)
PNY (ip, jp, kp, 8) = a21*PNQ (jp, kp, 8) + a22*PNE (ip, kp, 8) + a23*PNT (ip, jp, 8)

```

```

PNZ (ip, jp, kp, 1) = a31*PNQ (jp, kp, 1) + a32*PNE (ip, kp, 1) + a33*PNT (ip, jp, 1)
PNZ (ip, jp, kp, 2) = a31*PNQ (jp, kp, 2) + a32*PNE (ip, kp, 2) + a33*PNT (ip, jp, 2)
PNZ (ip, jp, kp, 3) = a31*PNQ (jp, kp, 3) + a32*PNE (ip, kp, 3) + a33*PNT (ip, jp, 3)
PNZ (ip, jp, kp, 4) = a31*PNQ (jp, kp, 4) + a32*PNE (ip, kp, 4) + a33*PNT (ip, jp, 4)
PNZ (ip, jp, kp, 5) = a31*PNQ (jp, kp, 5) + a32*PNE (ip, kp, 5) + a33*PNT (ip, jp, 5)
PNZ (ip, jp, kp, 6) = a31*PNQ (jp, kp, 6) + a32*PNE (ip, kp, 6) + a33*PNT (ip, jp, 6)
PNZ (ip, jp, kp, 7) = a31*PNQ (jp, kp, 7) + a32*PNE (ip, kp, 7) + a33*PNT (ip, jp, 7)
PNZ (ip, jp, kp, 8) = a31*PNQ (jp, kp, 8) + a32*PNE (ip, kp, 8) + a33*PNT (ip, jp, 8)

```

```

enddo
enddo
enddo

```

$$\begin{Bmatrix} \frac{\partial N_i}{\partial x} \\ \frac{\partial N_i}{\partial y} \\ \frac{\partial N_i}{\partial z} \end{Bmatrix} = \begin{bmatrix} \frac{\partial x}{\partial \xi} & \frac{\partial y}{\partial \xi} & \frac{\partial z}{\partial \xi} \\ \frac{\partial x}{\partial \eta} & \frac{\partial y}{\partial \eta} & \frac{\partial z}{\partial \eta} \\ \frac{\partial x}{\partial \zeta} & \frac{\partial y}{\partial \zeta} & \frac{\partial z}{\partial \zeta} \end{bmatrix}^{-1} \begin{Bmatrix} \frac{\partial N_i}{\partial \xi} \\ \frac{\partial N_i}{\partial \eta} \\ \frac{\partial N_i}{\partial \zeta} \end{Bmatrix} = \begin{bmatrix} a_{11} & a_{12} & a_{13} \\ a_{21} & a_{22} & a_{23} \\ a_{31} & a_{32} & a_{33} \end{bmatrix} \begin{Bmatrix} \frac{\partial N_i}{\partial \xi} \\ \frac{\partial N_i}{\partial \eta} \\ \frac{\partial N_i}{\partial \zeta} \end{Bmatrix}$$

MAT_ASS_MAIN (5/6)

```

!C
!C== CONSTRUCT the GLOBAL MATRIX
do ie= 1, 8
  ip = nodLOCAL(ie)
do je= 1, 8
  jp = nodLOCAL(je)

  kk= 0
  if (jp.ne.ip) then
    iiS= index(ip-1) + 1
    iiE= index(ip )
    do k= iiS, iiE
      if ( item(k).eq.jp ) then
        kk= k
        exit
      endif
    enddo
  endif
endif

```

Non-Zero Off-Diagonal Block
in Global Matix

$$A_{ip,jp}$$

kk: address in “item”

ip= nodLOCAL[ie]
jp= nodLOCAL[je]

Node ID (ip,jp)
starting from 1

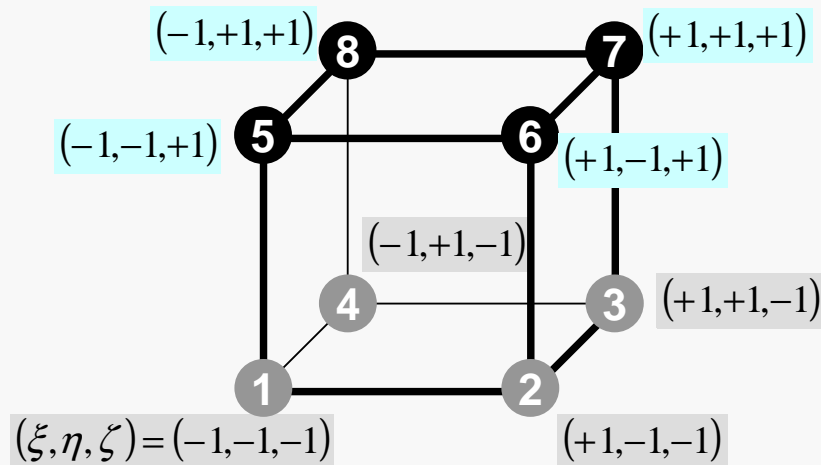

Element Matrix: 8x8

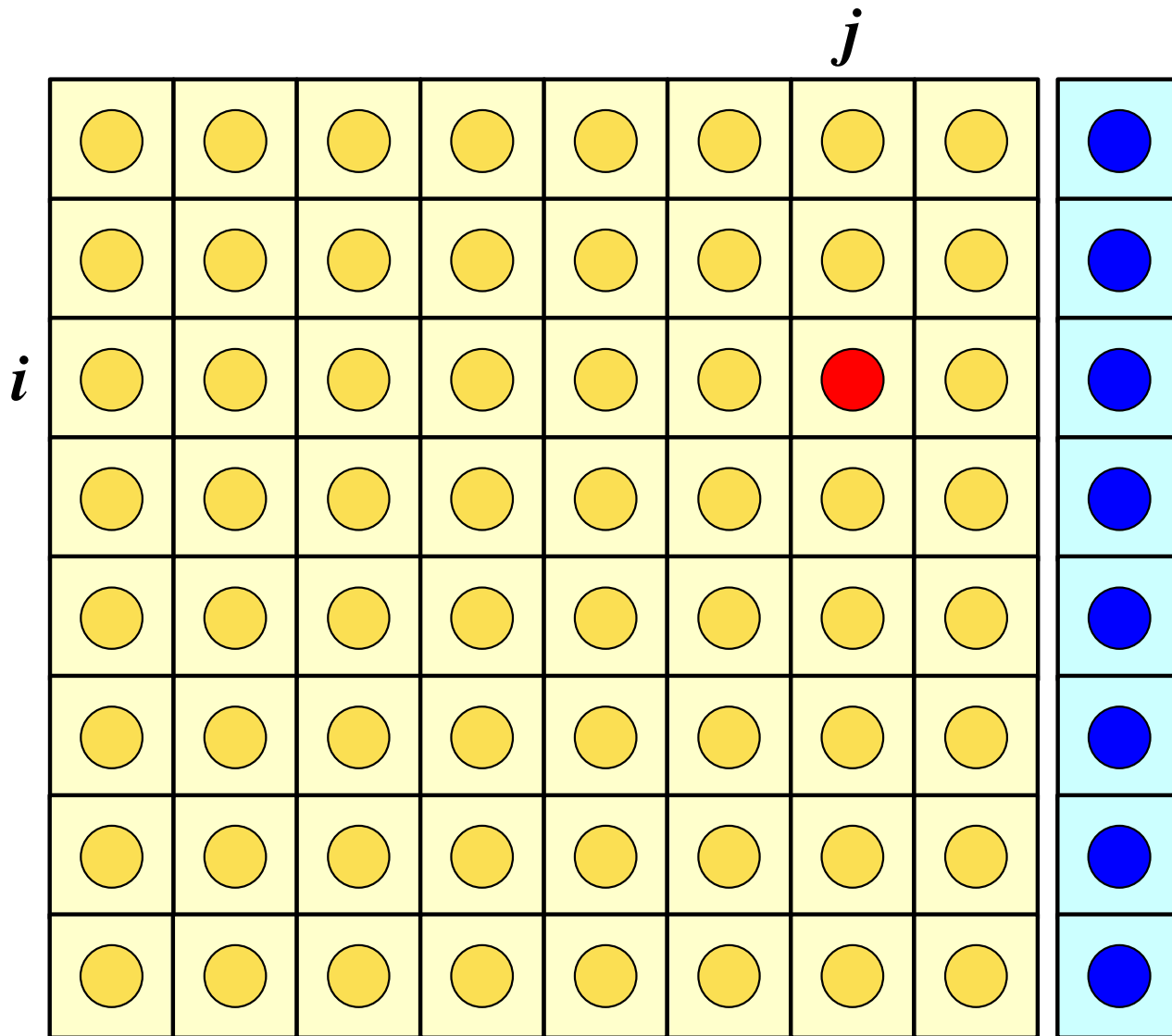

$$[k_{ij}] \quad (i, j = 1 \dots 8)$$

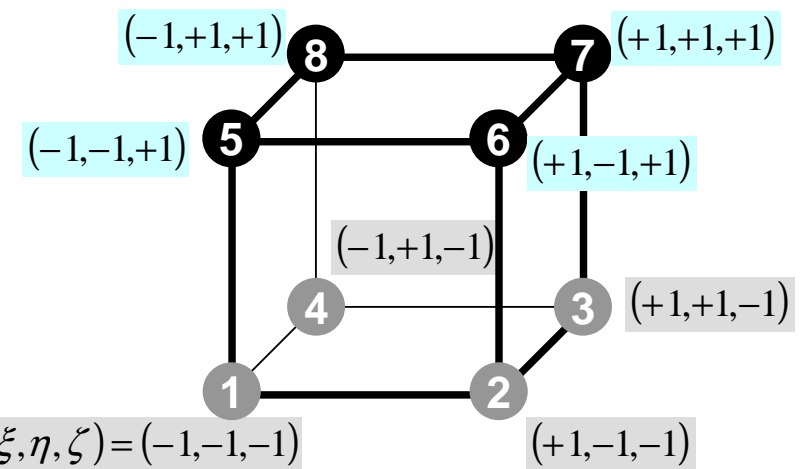

MAT_ASS_MAIN (5/6)

```

!C
!C== CONSTRUCT the GLOBAL MATRIX
do ie= 1, 8
  ip = nodLOCAL(ie)
do je= 1, 8
  jp = nodLOCAL(je)

  kk= 0
  if (jp.ne.ip) then
    iiS= index(ip-1) + 1
    iiE= index(ip )
    do k= iiS, iiE
      if ( item(k).eq.jp ) then
        kk= k
        exit
      endif
    enddo
  endif
endif

```

Element Matrix ($i_e \sim j_e$): Local ID
 Global Matrix ($i_p \sim j_p$): Global ID

kk: address in "item" starting from "1"

k: starting from "1"

ip,jp: starting from "1"

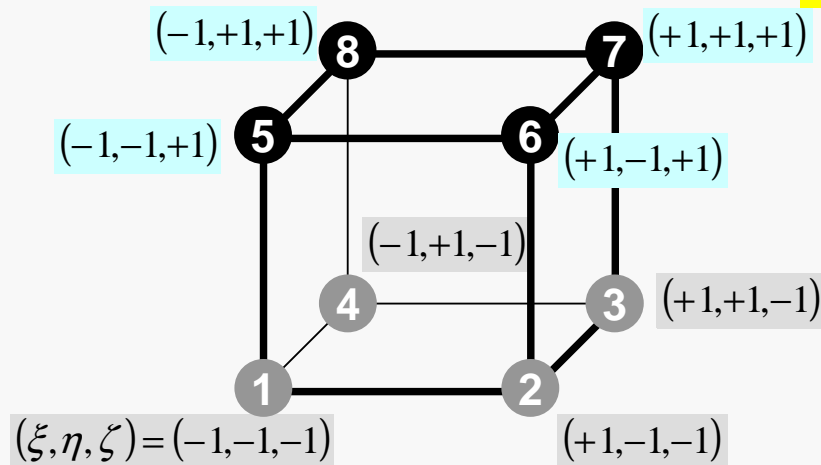

MAT_ASS_MAIN (6/6)

```

QVO = 0. d0
COEFij= 0. d0
do kpn= 1, 2
do jpn= 1, 2
do ipn= 1, 2
  coef= WEI (ipn)*WEI (jpn)*WEI (kpn)

  PNXi= PNX (ipn, jpn, kpn, ie)
  PNYi= PNY (ipn, jpn, kpn, ie)
  PNZi= PNZ (ipn, jpn, kpn, ie)

  PNXj= PNX (ipn, jpn, kpn, je)
  PNYj= PNY (ipn, jpn, kpn, je)
  PNZj= PNZ (ipn, jpn, kpn, je)

  COEFij= COEFij + coef * CONDO *
&          (PNXi*PNXj+PNYi*PNYj+PNZi*PNZj) *
&          DETJ(ipn, jpn, kpn)

  SHi= SHAPE (ipn, jpn, kpn, ie)
  QVO= QVO + SHi * QVOL * coef * DETJ(ipn, jpn, kpn)
enddo
enddo
enddo

if (jp. eq. ip) then
  D(ip)= D(ip) + COEFij
  B(ip)= B(ip) + QVO*QVC
else
  AMAT(kk)= AMAT(kk) + COEFij
endif
enddo
enddo
enddo

return
end

```

$$\int_{-1}^{+1} \int_{-1}^{+1} \int_{-1}^{+1} \left\{ \lambda \frac{\partial N_i}{\partial x} \frac{\partial N_j}{\partial x} + \lambda \frac{\partial N_i}{\partial y} \frac{\partial N_j}{\partial y} + \lambda \frac{\partial N_i}{\partial z} \frac{\partial N_j}{\partial z} \right\} \det|J| d\xi d\eta d\zeta$$

MAT_ASS_MAIN (6/6)

```

QVO = 0. d0
COEFij= 0. d0
do kpn= 1, 2
do jpn= 1, 2
do ipn= 1, 2
  coef= WEI (ipn)*WEI (jpn)*WEI (kpn)

  PNXi= PNX (ipn, jpn, kpn, ie)
  PNYi= PNY (ipn, jpn, kpn, ie)
  PNZi= PNZ (ipn, jpn, kpn, ie)

  PNXj= PNX (ipn, jpn, kpn, je)
  PNYj= PNY (ipn, jpn, kpn, je)
  PNZj= PNZ (ipn, jpn, kpn, je)

  COEFij= COEFij + coef * CONDO *
&      (PNXi*PNXj+PNYi*PNYj+PNZi*PNZj) *
&      DETJ (ipn, jpn, kpn)

  SHi= SHAPE (ipn, jpn, kpn, ie)
  QVO= QVO + SHi * QVOL * coef * DETJ (ipn, jpn, kpn)
enddo
enddo
enddo

if (jp. eq. ip) then
  D (ip)= D (ip) + COEFij
  B (ip)= B (ip) + QVO*QVC
else
  AMAT (kk)= AMAT (kk) + COEFij
endif
enddo
enddo
enddo

return
end

```

$$\begin{aligned}
 I &= \int_{-1}^{+1} \int_{-1}^{+1} \int_{-1}^{+1} f(\xi, \eta, \zeta) d\xi d\eta d\zeta \\
 &= \sum_{i=1}^L \sum_{j=1}^M \sum_{k=1}^N \boxed{W_i \cdot W_j \cdot W_k} \cdot \boxed{f(\xi_i, \eta_j, \zeta_k)}
 \end{aligned}$$

$$\int_{-1}^{+1} \int_{-1}^{+1} \int_{-1}^{+1} \left\{ \lambda \frac{\partial N_i}{\partial x} \frac{\partial N_j}{\partial x} + \lambda \frac{\partial N_i}{\partial y} \frac{\partial N_j}{\partial y} + \lambda \frac{\partial N_i}{\partial z} \frac{\partial N_j}{\partial z} \right\} \det |J| d\xi d\eta d\zeta$$

MAT_ASS_MAIN (6/6)

```
do kpn= 1, 2
do jpn= 1, 2
do ipn= 1, 2
coef= WEI (ipn)*WEI (jpn)*WEI (kpn)
```

```
PNXi= PNx (ipn, jpn, kpn, ie)
PNYi= PNY (ipn, jpn, kpn, ie)
PNZi= PNz (ipn, jpn, kpn, ie)
```

```
PNXj= PNx (ipn, jpn, kpn, je)
PNYj= PNY (ipn, jpn, kpn, je)
PNZj= PNz (ipn, jpn, kpn, je)
```

$$\text{coef} = W_i \cdot W_j \cdot W_k$$

$$I = \int_{-1}^{+1} \int_{-1}^{+1} \int_{-1}^{+1} f(\xi, \eta, \zeta) d\xi d\eta d\zeta$$

$$= \sum_{i=1}^L \sum_{j=1}^M \sum_{k=1}^N W_i \cdot W_j \cdot W_k \cdot f(\xi_i, \eta_j, \zeta_k)$$

```
& COEFij= COEFij + coef * CONDO * (PNXi*PNXj+PNYi*PNYj+PNZi*PNZj) *
DETJ (ipn, jpn, kpn)
```

```
enddo
enddo
enddo
```

$$\int_{-1}^{+1} \int_{-1}^{+1} \int_{-1}^{+1} \left\{ \lambda \frac{\partial N_i}{\partial x} \frac{\partial N_j}{\partial x} + \lambda \frac{\partial N_i}{\partial y} \frac{\partial N_j}{\partial y} + \lambda \frac{\partial N_i}{\partial z} \frac{\partial N_j}{\partial z} \right\} \det|J| d\xi d\eta d\zeta$$

MAT_ASS_MAIN (6/6)

```
do kpn= 1, 2
do jpn= 1, 2
do ipn= 1, 2
  coef= WEI (ipn)*WEI (jpn)*WEI (kpn)
```

```
  PNXi= PNx (ipn, jpn, kpn, ie)
  PNYi= PNY (ipn, jpn, kpn, ie)
  PNZi= PNz (ipn, jpn, kpn, ie)
```

```
  PNXj= PNx (ipn, jpn, kpn, je)
  PNYj= PNY (ipn, jpn, kpn, je)
  PNZj= PNz (ipn, jpn, kpn, je)
```

$$\text{coef} = W_i \cdot W_j \cdot W_k$$

$$I = \int_{-1}^{+1} \int_{-1}^{+1} \int_{-1}^{+1} f(\xi, \eta, \zeta) d\xi d\eta d\zeta$$

$$= \sum_{i=1}^L \sum_{j=1}^M \sum_{k=1}^N W_i \cdot W_j \cdot W_k \cdot f(\xi_i, \eta_j, \zeta_k)$$

```
& COEFij= COEFij + coef * CONDO * (PNXi*PNXj+PNYi*PNYj+PNZi*PNZj) *
  DETJ (ipn, jpn, kpn)
```

```
enddo
enddo
enddo
```

$$\int_{-1}^{+1} \int_{-1}^{+1} \int_{-1}^{+1} \left\{ \lambda \frac{\partial N_i}{\partial x} \frac{\partial N_j}{\partial x} + \lambda \frac{\partial N_i}{\partial y} \frac{\partial N_j}{\partial y} + \lambda \frac{\partial N_i}{\partial z} \frac{\partial N_j}{\partial z} \right\} \det|J| d\xi d\eta d\zeta$$

MAT_ASS_MAIN (6/6)

```

QVO = 0. d0
COEFij= 0. d0
do kpn= 1, 2
do jpn= 1, 2
do ipn= 1, 2
  coef= WEI (ipn)*WEI (jpn)*WEI (kpn)

  PNXi= PNX (ipn, jpn, kpn, ie)
  PNYi= PNY (ipn, jpn, kpn, ie)
  PNZi= PNZ (ipn, jpn, kpn, ie)

  PNXj= PNX (ipn, jpn, kpn, je)
  PNYj= PNY (ipn, jpn, kpn, je)
  PNZj= PNZ (ipn, jpn, kpn, je)

  COEFij= COEFij + coef * CONDO *
&      (PNXi*PNXj+PNYi*PNYj+PNZi*PNZj) *
&      DETJ(ipn, jpn, kpn)

  SHi= SHAPE(ipn, jpn, kpn, ie)
  QVO= QVO + SHi * QVOL * coef * DETJ(ipn, jpn, kpn)
enddo
enddo
enddo

if (jp. eq. ip) then
  D(ip)= D(ip) + COEFij
  B(ip)= B(ip) + QVO*QVC
else
  AMAT(kk)= AMAT(kk) + COEFij
endif
enddo
enddo
enddo

return
end

```

$$[k]^{(e)} \{\phi\}^{(e)} = \{f\}^{(e)}$$

$$\{f\}^{(e)} = \int_V \dot{Q}[N]^T dV$$

$$\dot{Q}(x, y, z) = QVOL |x_C + y_C|$$

$$QVC = |x_C + y_C|$$

$$QV0 = \int_V QVOL [N]^T dV$$

$$\{f\}^{(e)} = QV0 \cdot QVC$$

MAT_ASS_MAIN (6/6)

```

do kpn= 1, 2
do jpn= 1, 2
do ipn= 1, 2
  coef= WEI (ipn)*WEI (jpn)*WEI (kpn)

```

$$\text{coef} = W_i \cdot W_j \cdot W_k$$

```

  SHi= SHAPE (ipn, jpn, kpn, ie)

```

```

  QVO= QVO + SHi * QVOL * coef * DETJ (ipn, jpn, kpn)

```

```

enddo
enddo
enddo

```

$$\begin{aligned}
 I &= \int_{-1}^{+1} \int_{-1}^{+1} \int_{-1}^{+1} f(\xi, \eta, \zeta) d\xi d\eta d\zeta \\
 &= \sum_{i=1}^L \sum_{j=1}^M \sum_{k=1}^N \boxed{W_i \cdot W_j \cdot W_k} \cdot \boxed{f(\xi_i, \eta_j, \zeta_k)}
 \end{aligned}$$

$$\int_V QVOL [N]^T dV = \iiint QVOL [N] dx dy dz = \int_{-1}^{+1} \int_{-1}^{+1} \int_{-1}^{+1} \boxed{\{QVOL N_i\} \det |J|} d\xi d\eta d\zeta$$

MAT_ASS_MAIN (6/6)

```
do kpn= 1, 2
do jpn= 1, 2
do ipn= 1, 2
  coef= WEI (ipn)*WEI (jpn)*WEI (kpn)
```

$$\text{coef} = W_i \cdot W_j \cdot W_k$$

```
  SHi= SHAPE (ipn, jpn, kpn, ie)
```

```
  QVO= QVO + SHi * QVOL * coef * DETJ (ipn, jpn, kpn)
```

```
enddo
enddo
enddo
```

$$I = \int_{-1}^{+1} \int_{-1}^{+1} \int_{-1}^{+1} f(\xi, \eta, \zeta) d\xi d\eta d\zeta$$

$$= \sum_{i=1}^L \sum_{j=1}^M \sum_{k=1}^N W_i \cdot W_j \cdot W_k \cdot f(\xi_i, \eta_j, \zeta_k)$$

$$\int_V QVOL [N]^T dV = \iiint QVOL [N] dx dy dz = \int_{-1}^{+1} \int_{-1}^{+1} \int_{-1}^{+1} \{ QVOL N_i \} \det |J| d\xi d\eta d\zeta$$

MAT_ASS_MAIN (6/6)

```

QVO = 0. d0
COEFij= 0. d0
do kpn= 1, 2
do jpn= 1, 2
do ipn= 1, 2
  coef= WEI (ipn)*WEI (jpn)*WEI (kpn)

  PNXi= PNX (ipn, jpn, kpn, ie)
  PNYi= PNY (ipn, jpn, kpn, ie)
  PNZi= PNZ (ipn, jpn, kpn, ie)

  PNXj= PNX (ipn, jpn, kpn, je)
  PNYj= PNY (ipn, jpn, kpn, je)
  PNZj= PNZ (ipn, jpn, kpn, je)

  COEFij= COEFij + coef * CONDO *
&      (PNXi*PNXj+PNYi*PNYj+PNZi*PNZj) *
&      DETJ(ipn, jpn, kpn)

  SHi= SHAPE(ipn, jpn, kpn, ie)
  QVO= QVO + SHi * QVOL * coef * DETJ(ipn, jpn, kpn)
enddo
enddo
enddo

if (jp. eq. ip) then
  D(ip)= D(ip) + COEFij
  B(ip)= B(ip) + QVO*QVC
else
  AMAT(kk)= AMAT(kk) + COEFij
endif
enddo
enddo
enddo

return
end

```

$$[k]^{(e)} \{\phi\}^{(e)} = \{f\}^{(e)}$$

$$\{f\}^{(e)} = \int_V \dot{Q}[N]^T dV$$

$$\dot{Q}(x, y, z) = QVOL |x_c + y_c|$$

$$QVO = \int_V QVOL [N]^T dV$$

$$QVC = |x_c + y_c|$$

$$\{f\}^{(e)} = QVO \cdot QVC$$

MAT_ASS_BC: Overview

```
do i= 1, N      Loop for Nodes
  "Mark" nodes where Dirichlet B.C. are applied (IWKX)
enddo
```

```
do i= 1, N      Loop for Nodes
  if (IWKX(i,1).eq.1) then  if "marked" nodes
    corresponding components of RHS (B),
    Diagonal (D) are corrected
    do k= index(i-1)+1, index(i)  Non-Zero Off-Diagonal Nodes
      corresponding comp. of non-zero off-diagonal
      components (AMAT) are corrected
    enddo
  endif
enddo
```

```
do i= 1, N      Loop for Nodes
  do k= index(i-1)+1, index(i)  Non-Zero Off-Diagonal Nodes
    if (IWKX(item(k),1).eq.1) then
      corresponding components of RHS and AMAT are corrected (col.)
    endif
  enddo
enddo
```

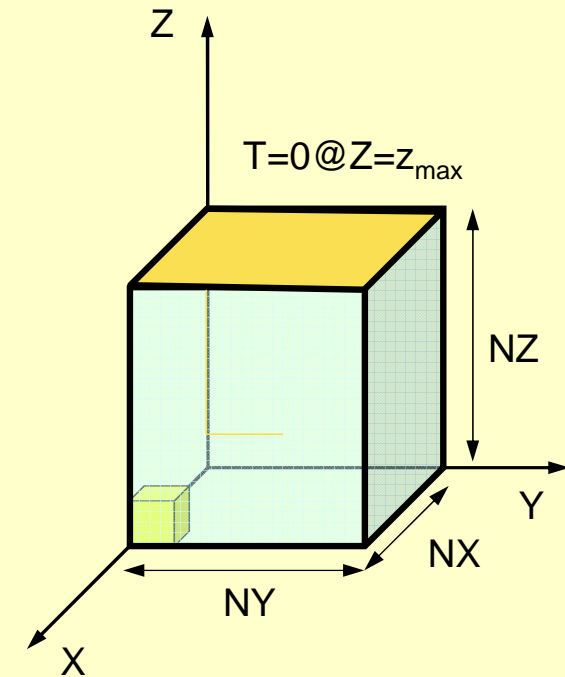

MAT_ASS_BC (1/2)

```
subroutine MAT_ASS_BC
use pfem_util
implicit REAL*8 (A-H, O-Z)

allocate (IWKX(N, 2))
IWKX= 0

!C
!C== Z=Zmax

do in= 1, N
  IWKX(in, 1)= 0
enddo

ib0= -1
do ib0= 1, NODGRPtot
  if (NODGRP_NAME(ib0).eq.'Zmax') exit
enddo

do ib= NODGRP_INDEX(ib0-1)+1, NODGRP_INDEX(ib0)
  in= NODGRP_ITEM(ib)
  IWKX(in, 1)= 1
enddo
```

If the node “in” is included in the node group “Zmax”

$IWKX(in, 1) = 1$

MAT_ASS_BC (2/2)

```
do in= 1, N
  if (IWKX(in,1).eq.1) then
    B(in)= 0.d0
    D(in)= 1.d0

    iS= index(in-1) + 1
    iE= index(in )
    do k= iS, iE
      AMAT(k)= 0.d0
    enddo
  endif
enddo

do in= 1, N
  iS= index(in-1) + 1
  iE= index(in )
  do k= iS, iE
    if (IWKX(item(k),1).eq.1) then
      AMAT(k)= 0.d0
    endif
  enddo
enddo

!C==
return
end
```

1D Steady State Heat Conduction

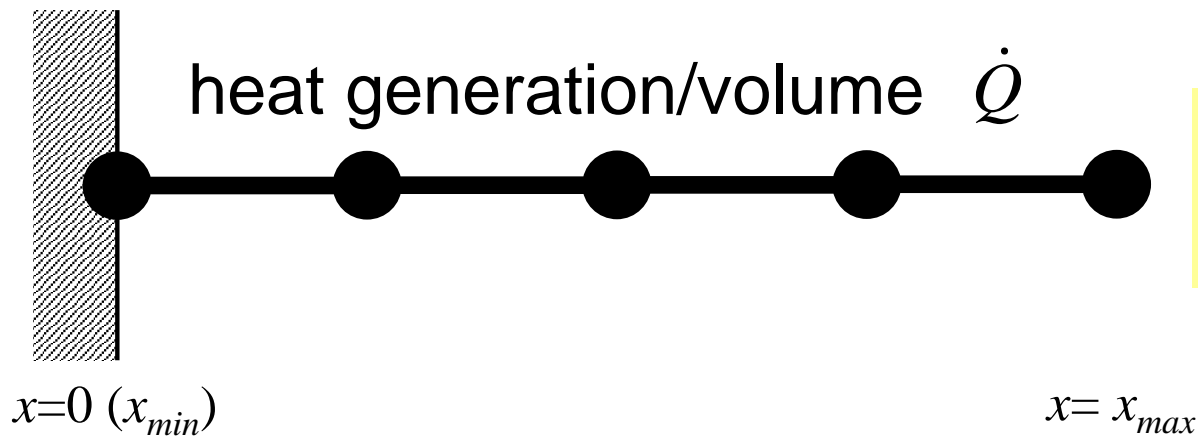

$$\frac{\partial}{\partial x} \left(\lambda \frac{\partial T}{\partial x} \right) + \dot{Q} = 0$$

- **Uniform: Sectional Area: A , Thermal Conductivity: λ**
- Heat Generation Rate/Volume/Time [$QL^{-3}T^{-1}$] \dot{Q}
- Boundary Conditions
 - $x=0$: $T=0$ (Fixed Temperature)
 - $x=x_{max}$: $\frac{\partial T}{\partial x} = 0$ (Insulated)

(Linear) Equation at $x=0$

$$T_1 = 0 \text{ (or } T_0 = 0)$$

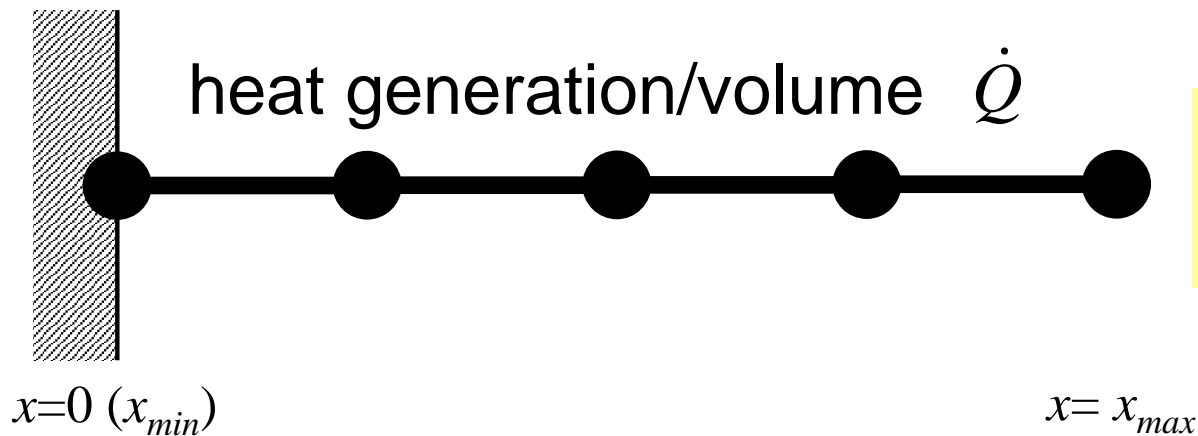

$$\frac{\partial}{\partial x} \left(\lambda \frac{\partial T}{\partial x} \right) + \dot{Q} = 0$$

- **Uniform: Sectional Area: A , Thermal Conductivity: λ**
- Heat Generation Rate/Volume/Time [$QL^{-3}T^{-1}$] \dot{Q}
- Boundary Conditions
 - $x=0$: $T=0$ (Fixed Temperature)
 - $x=x_{max}$: $\frac{\partial T}{\partial x} = 0$ (Insulated)

Program: 1d.f (6/6)

Dirichlet B.C. @ X=0

```

!C
!C +-----+
!C | BOUNDARY CONDITIONS |
!C +-----+
!C===

!C
!C-- X=Xmin
      i= 1
      js= INDEX(i-1)

      AMAT(js+1)= 0. d0
      DIAG(i)= 1. d0
      RHS (i)= 0. d0

      do k= 1, NPLU
        if (ITEM(k).eq.1) AMAT(k)= 0. d0
      enddo
!C===

```

$$T_1=0$$

Diagonal Component=1

RHS=0

Off-Diagonal Components= 0.

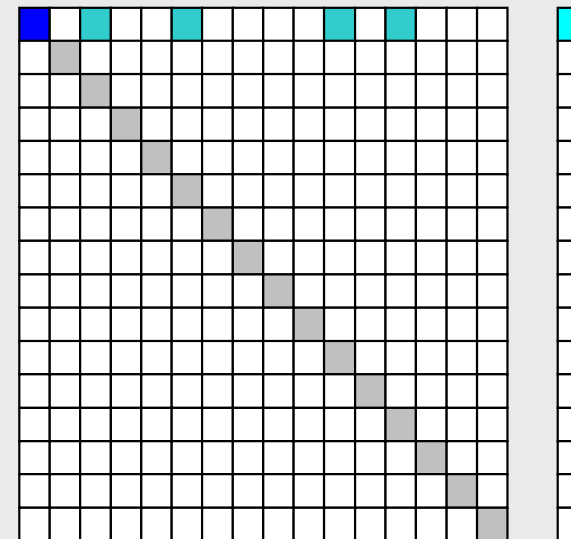

Program: 1d.f (6/6)

Dirichlet B.C. @ X=0

```

!C
!C +-----+
!C | BOUNDARY CONDITIONS |
!C +-----+
!C===

!C
!C-- X=Xmin
  i= 1
  jS= INDEX(i-1)

  AMAT(jS+1)= 0. d0
  DIAG(i)= 1. d0
  RHS (i)= 0. d0

  do k= 1, NPLU
    if (ITEM(k).eq.1) AMAT(k)= 0. d0
  enddo
!C===

```

$$T_1=0$$

Diagonal Component=1

RHS=0

Off-Diagonal Components= 0.

Erase !

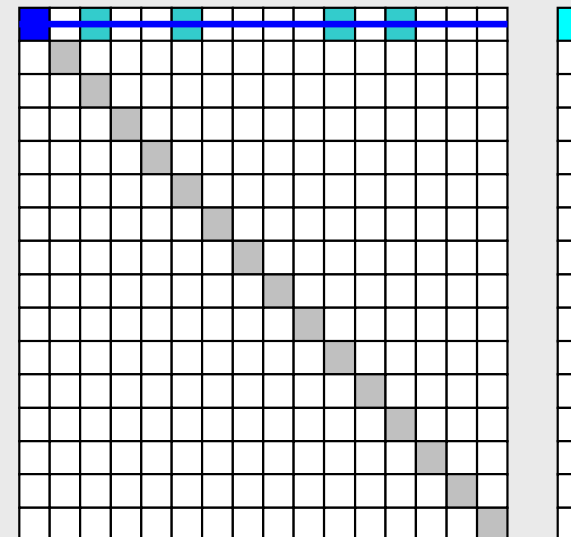

Program: 1d.f (6/6)

Dirichlet B.C. @ X=0

```

!C
!C +-----+
!C | BOUNDARY CONDITIONS |
!C +-----+
!C===

!C
!C-- X=Xmin
      i= 1
      jS= INDEX(i-1)

      AMAT(jS+1)= 0. d0
      DIAG(i)= 1. d0
      RHS (i)= 0. d0

      do k= 1, NPLU
        if (ITEM(k).eq.1) AMAT(k)= 0. d0
      enddo
!C===

```

$$T_1=0$$

Diagonal Component=1

RHS=0

Off-Diagonal Components= 0.

Elimination and Erase

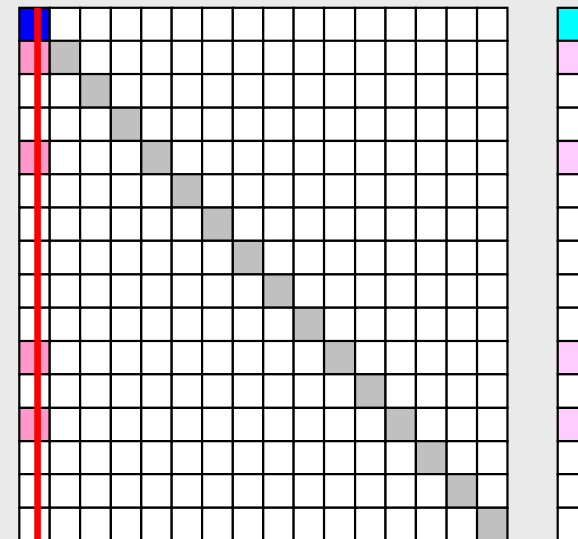

Column components of boundary nodes (Dirichlet B.C.) are moved to RHS and eliminated for keeping symmetrical feature of the matrix (in this case just erase off-diagonal components)

if $T_1 \neq 0$

```

!C
!C +-----+
!C | BOUNDARY CONDITIONS |
!C +-----+
!C===

!C
!C-- X=Xmin
      i= 1
      js= INDEX(i-1)

      AMAT(js+1)= 0. d0
      DIAG(i)= 1. d0
      RHS (i)= PHImin

      do i= 1, N
        do k= INDEX(i-1)+1, INDEX(i)
          if (ITEM(k).eq.1) then
            RHS (i)= RHS(i) - AMAT(k)*PHImin
            AMAT(k)= 0. d0
          endif
        enddo
      enddo
!C===

```

Column components of boundary nodes (Dirichlet B.C.) are moved to RHS and eliminated for keeping symmetrical feature of the matrix.

$$Diag_j \phi_j + \sum_{k=Index[j]}^{Index[j+1]-1} Amat_k \phi_{Item[k]} = Rhs_j$$

if $T_1 \neq 0$

```

!C
!C +-----+
!C | BOUNDARY CONDITIONS |
!C +-----+
!C===

!C
!C-- X=Xmin
      i= 1
      js= INDEX(i-1)

      AMAT(js+1)= 0. d0
      DIAG(i)= 1. d0
      RHS (i)= PHImin

      do i= 1, N
        do k= INDEX(i-1)+1, INDEX(i)
          if (ITEM(k).eq.1) then
            RHS (i)= RHS(i) - AMAT(k)*PHImin
            AMAT(k)= 0. d0
          endif
        enddo
      enddo
!C===

```

$$\begin{aligned}
 & \text{Diag}_j \phi_j + \sum_{k=\text{Index}[j], k \neq k_s}^{\text{Index}[j+1]-1} \text{Amat}_k \phi_{\text{Item}[k]} \\
 &= \text{Rhs}_j - \text{Amat}_{k_s} \phi_{\text{Item}[k_s]} \\
 &= \text{Rhs}_j - \text{Amat}_{k_s} \phi_{\min} \quad \text{where } \text{Item}[k_s] = 1
 \end{aligned}$$

Column components of boundary nodes (Dirichlet B.C.) are moved to RHS and eliminated for keeping symmetrical feature of the matrix.

MAT_ASS_BC (2/2)

```
do in= 1, N
  if (IWKX(in,1).eq.1) then
    B(in)= 0.d0
    D(in)= 1.d0
```

```
    iS= index(in-1) + 1
    iE= index(in )
    do k= iS, iE
      AMAT(k)= 0.d0
    enddo
  endif
enddo
```

```
do in= 1, N
  iS= index(in-1) + 1
  iE= index(in )
  do k= iS, iE
    if (IWKX(item(k),1).eq.1) then
      AMAT(k)= 0.d0
    endif
  enddo
enddo
```

```
!C==
```

```
return
end
```

Boundary Nodes:
IWKX(in,1)=1

Erase !!

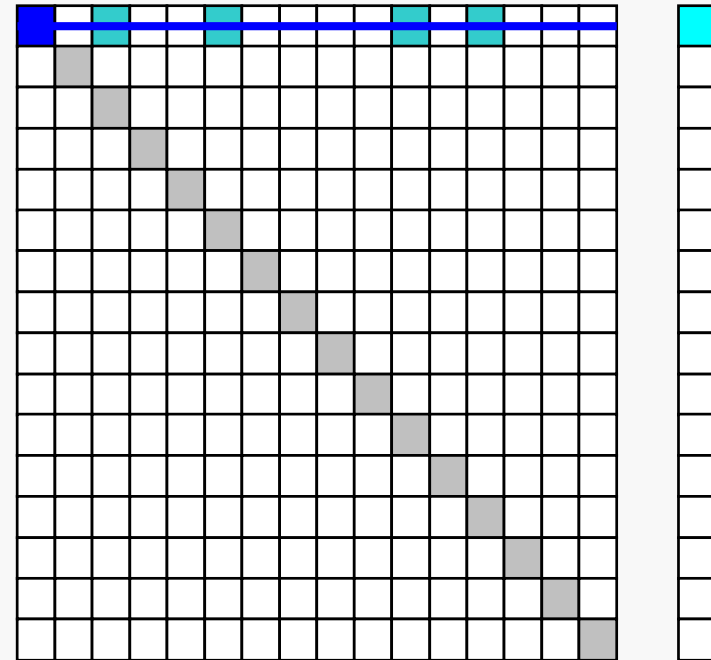

Same as 1D case

MAT_ASS_BC (2/2)

```
do in= 1, N
  if (IWKX(in,1).eq.1) then
    B(in)= 0.d0
    D(in)= 1.d0
```

```
    iS= index(in-1) + 1
    iE= index(in )
    do k= iS, iE
      AMAT(k)= 0.d0
    enddo
  endif
enddo
```

```
do in= 1, N
  iS= index(in-1) + 1
  iE= index(in )
  do k= iS, iE
    if (IWKX(item(k),1).eq.1) then
      AMAT(k)= 0.d0
    endif
  enddo
enddo
```

```
!C==
```

```
return
end
```

Boundary Nodes:
IWKX(in,1)=1

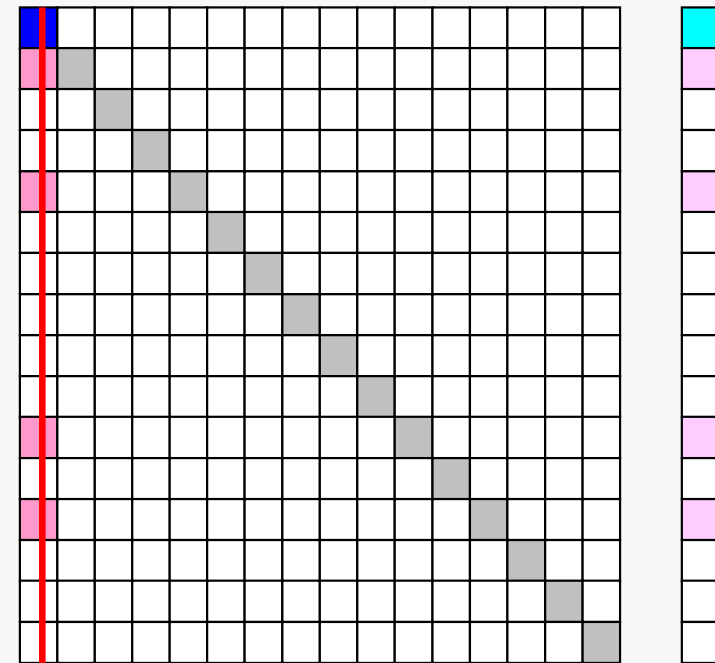

**Elimination and
Erase**

Same as 1D case

Structure of heat3D

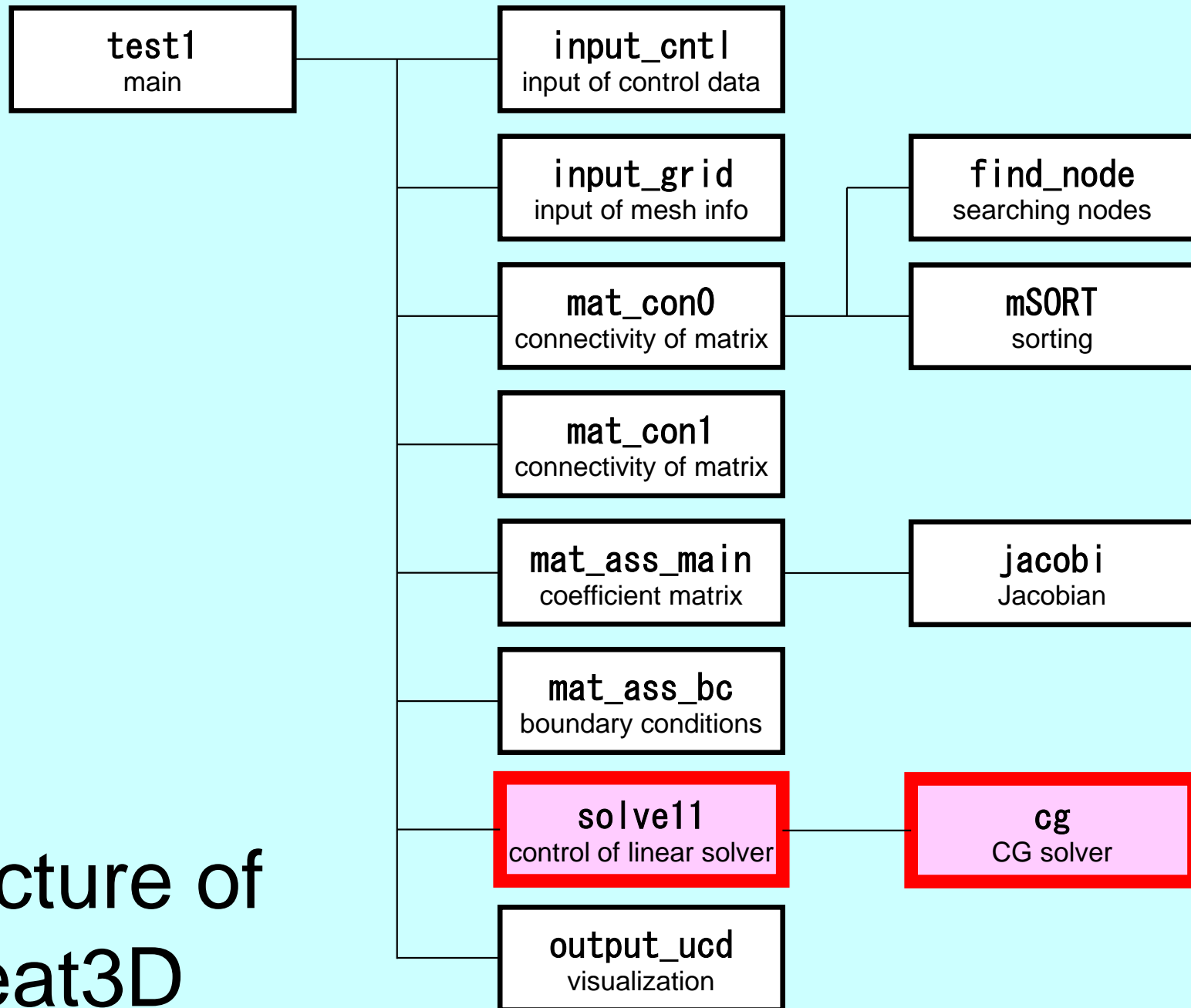

Main Part

```

program heat3D

use solver11
use pfem_util

implicit REAL*8(A-H, O-Z)

call INPUT_CNTL
call INPUT_GRID

call MAT_CONO
call MAT_CON1

call MAT_ASS_MAIN
call MAT_ASS_BC

call SOLVE11

call OUTPUT_UCD

do i= 1, N
  if (XYZ(i, 1).eq. 0. d0. and. XYZ(i, 2).eq. 0. d0
& .and. XYZ(i, 3).eq. 0. d0) then
    write (*, '(i8, 1pe16.6)') i, X(i)
  endif
enddo

end program heat3D

```

```

1 4.025833e+00
2 3.628020e+00
3 3.319234e+00
4 3.073771e+00
(...)
55 9.238550e-07
56 3.876258e-07
57 1.854812e-07
58 1.062119e-07
59 3.541404e-08
60 1.284087e-08
61 6.073277e-09

1 3.391200e+03

```

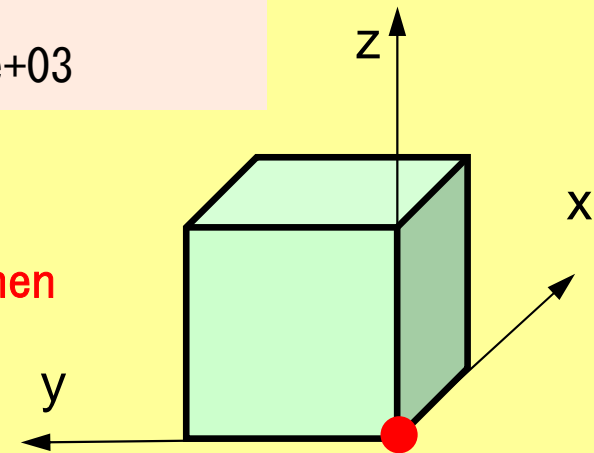

SOLVE11

```

module SOLVER11
contains
  subroutine SOLVE11

    use pfem_util
    use solver_CG

    implicit REAL*8 (A-H, O-Z)

    integer :: ERROR, ICFLAG
    character(len=char_length) :: BUF

    data ICFLAG/0/

!C
!C +-----+
!C | PARAMETERS |
!C +-----+
!C===
      ITER      = pfemIarray(1)
      RESID     = pfemRarray(1)
!C
!C===
      Max. Iterations for CG
      Convergence Criteria for CG

!C
!C +-----+
!C | ITERATIVE solver |
!C +-----+
!C===
      call CG
      & ( N, NPLU, D, AMAT, index, item, B, X, RESID, ITER, ERROR ) &

      ITERactual= ITER
!C===

    end subroutine SOLVE11
  end module SOLVER11

```

Preconditioned CG Solver

Diagonal Scaling/Point Jacobi Preconditioning

```

Compute  $\mathbf{r}^{(0)} = \mathbf{b} - [\mathbf{A}]\mathbf{x}^{(0)}$ 
for i= 1, 2, ...
  solve  $[\mathbf{M}]\mathbf{z}^{(i-1)} = \mathbf{r}^{(i-1)}$ 
   $\rho_{i-1} = \mathbf{r}^{(i-1)} \mathbf{z}^{(i-1)}$ 
  if i=1
     $\mathbf{p}^{(1)} = \mathbf{z}^{(0)}$ 
  else
     $\beta_{i-1} = \rho_{i-1} / \rho_{i-2}$ 
     $\mathbf{p}^{(i)} = \mathbf{z}^{(i-1)} + \beta_{i-1} \mathbf{p}^{(i-1)}$ 
  endif
   $\mathbf{q}^{(i)} = [\mathbf{A}]\mathbf{p}^{(i)}$ 
   $\alpha_i = \rho_{i-1} / \mathbf{p}^{(i)} \mathbf{q}^{(i)}$ 
   $\mathbf{x}^{(i)} = \mathbf{x}^{(i-1)} + \alpha_i \mathbf{p}^{(i)}$ 
   $\mathbf{r}^{(i)} = \mathbf{r}^{(i-1)} - \alpha_i \mathbf{q}^{(i)}$ 
  check convergence  $|\mathbf{r}|$ 
end

```

$$[\mathbf{M}] = \begin{bmatrix} D_1 & 0 & \dots & 0 & 0 \\ 0 & D_2 & & 0 & 0 \\ \dots & & \dots & & \dots \\ 0 & 0 & & D_{N-1} & 0 \\ 0 & 0 & \dots & 0 & D_N \end{bmatrix}$$

Diagonal Scaling, Point-Jacobi

$$[M] = \begin{bmatrix} D_1 & 0 & \dots & 0 & 0 \\ 0 & D_2 & & 0 & 0 \\ \dots & & \dots & & \dots \\ 0 & 0 & & D_{N-1} & 0 \\ 0 & 0 & \dots & 0 & D_N \end{bmatrix}$$

- **solve** $[M]\mathbf{z}^{(i-1)} = \mathbf{r}^{(i-1)}$ is very easy.
- Provides fast convergence for simple problems.

CG Solver (1/6)

```
module solver_CG
contains
```

```
subroutine CG &
& (N, NPLU, D, AMAT, index, item, B, X, RESID, ITER, ERROR) &
```

```
implicit REAL*8(A-H, O-Z)
include 'precision.inc'
```

```
integer(kind=kint), intent(in):: N, NPLU
integer(kind=kint), intent(inout):: ITER, ERROR
real(kind=kreal), intent(inout):: RESID
real(kind=kreal), dimension(N), intent(inout):: B, X, D
real(kind=kreal), dimension(NPLU), intent(inout):: AMAT
integer(kind=kint), dimension(0:N), intent(in):: index
integer(kind=kint), dimension(NPLU), intent(in):: item
```

```
real(kind=kreal), dimension(:, :), allocatable :: WW
```

```
integer(kind=kint), parameter :: R= 1
integer(kind=kint), parameter :: Z= 2
integer(kind=kint), parameter :: Q= 2
integer(kind=kint), parameter :: P= 3
integer(kind=kint), parameter :: DD= 4
```

```
integer(kind=kint) :: MAXIT
real(kind=kreal) :: TOL, W, SS
```

Variables/Arrays in CG Solver

Name	Type	Size	I/O	Definition
N, NP	I		I	# Node
NPLU	I		O	# Non-Zero Off-Diagonals
D	R	(N)	O	Diagonal Block of Global Matrix
B, X	R	(N)	O	RHS, Unknown Vector
AMAT	R	(NPLU)	O	Non-Zero Off-Diagonal Components of Global Matrix
index	I	(0:N)	O	# Non-Zero Off-Diagonal Components
item	I	(NPLU)	O	Column ID of Non-Zero Off-Diagonal Components
ITER	I		I/O	Number of CG Iterations (MAX: In, Actual: Out)
RESID	R		I/O	Convergence Criteria (In), Final Residual Norm (Out)
MAXIT	I		-	Maximum Number of CG Iterations
TOL	R		-	Convergence Criteria
WW	R	(N, 4)	-	Work Arrays
P, Q, R, Z, DD	I		-	Vector ID for WW (1-4)

CG Solver (1/6)

```
module solver_CG
```

```
contains
```

```
WW (i, 1) = WW (i, R)   => {r}
WW (i, 2) = WW (i, Z)   => {z}
WW (i, 2) = WW (i, Q)   => {q}
WW (i, 3) = WW (i, P)   => {p}
WW (i, 4) = WW (i, DD) => 1/{D}
```

```
integer (kind=kint), intent(inout) :: ITER, LRROR
real (kind=kreal), intent(inout) :: RESID
real (kind=kreal), dimension(N), intent(inout) :: r
real (kind=kreal), dimension(NPLU), intent(inout) :: z
integer (kind=kint), dimension(0:N), intent(in) :: q
integer (kind=kint), dimension(NPLU), intent(in) :: p
```

```
real (kind=kreal), dimension(:, :), allocatable :: DD
```

```
integer (kind=kint), parameter :: R= 1
integer (kind=kint), parameter :: Z= 2
integer (kind=kint), parameter :: Q= 2
integer (kind=kint), parameter :: P= 3
integer (kind=kint), parameter :: DD= 4
```

```
integer (kind=kint) :: MAXIT
real (kind=kreal) :: TOL, W, SS
```

```
Compute  $r^{(0)} = b - [A]x^{(0)}$ 
for i = 1, 2, ...
  solve  $[M]z^{(i-1)} = r^{(i-1)}$ 
   $\rho_{i-1} = r^{(i-1)} \cdot z^{(i-1)}$ 
  if i = 1
     $p^{(1)} = z^{(0)}$ 
  else
     $\beta_{i-1} = \rho_{i-1} / \rho_{i-2}$ 
     $p^{(i)} = z^{(i-1)} + \beta_{i-1} p^{(i-1)}$ 
  endif
   $q^{(i)} = [A]p^{(i)}$ 
   $\alpha_i = \rho_{i-1} / p^{(i)} q^{(i)}$ 
   $x^{(i)} = x^{(i-1)} + \alpha_i p^{(i)}$ 
   $r^{(i)} = r^{(i-1)} - \alpha_i q^{(i)}$ 
  check convergence |r|
end
```

CG Solver (2/6)

```

!C
!C +-----+
!C | INIT. |
!C +-----+
!C===
      ERROR= 0
      allocate (WW(N,4))
      MAXIT = ITER
      TOL   = RESID
      X = 0. d0
!C===

!C +-----+
!C | {r0}= {b} - [A] {xini} |
!C +-----+
!C===
      do j= 1, N
      WW(j,DD)= 1. d0/D(j)
      WVAL= B(j) - D(j)*X(j)
      do k= index(j-1)+1, index(j)
      i= item(k)
      WVAL= WVAL - AMAT(k)*X(i)
      enddo
      WW(j,R)= WVAL
      enddo

```

$$\begin{aligned}
 WW(i, 1) &= WW(i, R) &\Rightarrow \{r\} \\
 WW(i, 2) &= WW(i, Z) &\Rightarrow \{z\} \\
 WW(i, 2) &= WW(i, Q) &\Rightarrow \{q\} \\
 WW(i, 3) &= WW(i, P) &\Rightarrow \{p\} \\
 WW(i, 4) &= WW(i, DD) &\Rightarrow 1/\{D\}
 \end{aligned}$$

Reciprocal numbers (倒数) of diagonal components are stored in $WW(i, DD)$. Computational cost for division is usually expensive.

CG Solver (2/6)

```

!C
!C +-----+
!C | INIT. |
!C +-----+
!C===
      ERROR= 0
      allocate (WW(N, 4))
      MAXIT = ITER
      TOL   = RESID
      X = 0. d0
!C===

!C +-----+
!C | {r0}= {b} - [A]{xini} |
!C +-----+
!C===
      do j= 1, N
        WW(j, DD)= 1. d0/D(j)
        WVAL= B(j) - D(j)*X(j)
        do k= index(j-1)+1, index(j)
          i= item(k)
          WVAL= WVAL - AMAT(k)*X(i)
        enddo
        WW(j, R)= WVAL
      enddo

```

Compute $\mathbf{r}^{(0)} = \mathbf{b} - [\mathbf{A}]\mathbf{x}^{(0)}$

```

for i= 1, 2, ...
  solve [M]z(i-1)= r(i-1)
  ρi-1 = r(i-1) z(i-1)
  if i=1
    p(1) = z(0)
  else
    βi-1 = ρi-1/ρi-2
    p(i) = z(i-1) + βi-1 p(i-1)
  endif
  q(i) = [A]p(i)
  αi = ρi-1/p(i)q(i)
  x(i) = x(i-1) + αip(i)
  r(i) = r(i-1) - αiq(i)
  check convergence |r|
end

```

CG Solver (3/6)

```

BNRM2= 0. d0
do i= 1, N
  BNRM2= BNRM2 + B(i)**2
enddo

if (BNRM2. eq. 0. d0) BNRM2= 1. d0
ITER = 0

```

**$BNRM2 = |b|^2$
for convergence criteria
of CG solvers**

```
!C===
```

```
do iter= 1, MAXIT
```

```
!C
```

```
!C***** Conjugate Gradient Iteration
```

```
!C
```

```
!C +-----+
```

```
!C | {z} = [Minv] {r} |
```

```
!C +-----+
```

```
!C===
```

```
do i= 1, N
```

```
  WW(i, Z) = WW(i, R) * WW(i, DD)
```

```
enddo
```

```
!C===
```

CG Solver (3/6)

```

BNRM2= 0. d0
do i= 1, N
  BNRM2= BNRM2 + B(i)**2
enddo

if (BNRM2. eq. 0. d0) BNRM2= 1. d0
ITER = 0
!C===

do iter= 1, MAXIT
!C
!C*****
!C
!C +-----+
!C | {z}= [Minv] {r} |
!C +-----+
!C===
do i= 1, N
  WW(i, Z)= WW(i, R) * WW(i, DD)
enddo
!C===

```

```

Compute  $r^{(0)} = b - [A]x^{(0)}$ 
for  $i = 1, 2, \dots$ 
  solve  $[M]z^{(i-1)} = r^{(i-1)}$ 
   $\rho_{i-1} = r^{(i-1)} z^{(i-1)}$ 
  if  $i=1$ 
     $p^{(1)} = z^{(0)}$ 
  else
     $\beta_{i-1} = \rho_{i-1} / \rho_{i-2}$ 
     $p^{(i)} = z^{(i-1)} + \beta_{i-1} p^{(i-1)}$ 
  endif
   $q^{(i)} = [A]p^{(i)}$ 
   $\alpha_i = \rho_{i-1} / p^{(i)} q^{(i)}$ 
   $x^{(i)} = x^{(i-1)} + \alpha_i p^{(i)}$ 
   $r^{(i)} = r^{(i-1)} - \alpha_i q^{(i)}$ 
  check convergence  $|r|$ 
end

```

CG Solver (4/6)

```

!C
!C +-----+
!C | {RHO}= {r} {z} |
!C +-----+
!C==
      RHO= 0. d0
      do i= 1, N
        RHO= RHO + WW(i, R)*WW(i, Z)
      enddo
!C==

!C +-----+
!C | {p} = {z} if      ITER=1      |
!C | BETA= RHO / RHO1 otherwise |
!C +-----+
!C==
      if ( ITER. eq. 1 ) then
        do i= 1, N
          WW(i, P)= WW(i, Z)
        enddo
      else
        BETA= RHO / RHO1
        do i= 1, N
          WW(i, P)= WW(i, Z) + BETA*WW(i, P)
        enddo
      endif
!C==

```

```

Compute  $r^{(0)} = b - [A]x^{(0)}$ 
for  $i = 1, 2, \dots$ 
  solve  $[M]z^{(i-1)} = r^{(i-1)}$ 
   $\rho_{i-1} = r^{(i-1)} z^{(i-1)}$ 
  if  $i=1$ 
     $p^{(1)} = z^{(0)}$ 
  else
     $\beta_{i-1} = \rho_{i-1} / \rho_{i-2}$ 
     $p^{(i)} = z^{(i-1)} + \beta_{i-1} p^{(i-1)}$ 
  endif
   $q^{(i)} = [A]p^{(i)}$ 
   $\alpha_i = \rho_{i-1} / p^{(i)} q^{(i)}$ 
   $x^{(i)} = x^{(i-1)} + \alpha_i p^{(i)}$ 
   $r^{(i)} = r^{(i-1)} - \alpha_i q^{(i)}$ 
  check convergence  $|r|$ 
end

```

CG Solver (5/6)

```

!C +-----+
!C | {q}= [A] {p} |
!C +-----+
!C===
      do j= 1, N
        WVAL= D(j)*WW(j, P)
        do k= index(j-1)+1, index(j)
          i= item(k)
          WVAL= WVAL + AMAT(k)*WW(i, P)
        enddo
        WW(j, Q)= WVAL
      enddo
!C===

!C +-----+
!C | ALPHA= RHO / {p} {q} |
!C +-----+
!C===
      C1= 0. d0
      do i= 1, N
        C1= C1 + WW(i, P)*WW(i, Q)
      enddo
      ALPHA= RHO / C1
!C===

```

```

Compute  $r^{(0)} = b - [A]x^{(0)}$ 
for  $i = 1, 2, \dots$ 
  solve  $[M]z^{(i-1)} = r^{(i-1)}$ 
   $\rho_{i-1} = r^{(i-1)} z^{(i-1)}$ 
  if  $i=1$ 
     $p^{(1)} = z^{(0)}$ 
  else
     $\beta_{i-1} = \rho_{i-1} / \rho_{i-2}$ 
     $p^{(i)} = z^{(i-1)} + \beta_{i-1} p^{(i-1)}$ 
  endif
   $q^{(i)} = [A]p^{(i)}$ 
   $\alpha_i = \rho_{i-1} / p^{(i)} q^{(i)}$ 
   $x^{(i)} = x^{(i-1)} + \alpha_i p^{(i)}$ 
   $r^{(i)} = r^{(i-1)} - \alpha_i q^{(i)}$ 
  check convergence  $|r|$ 
end

```

CG Solver (6/6)

```

!C
!C +-----+
!C | {x} = {x} + ALPHA*{p} |
!C | {r} = {r} - ALPHA*{q} |
!C +-----+
!C==
      do i = 1, N
          X(i) = X (i)  + ALPHA * WW(i, P)
          WW(i, R) = WW(i, R) - ALPHA * WW(i, Q)
      enddo
!C==
      DNRM2 = 0. d0
      do i = 1, N
          DNRM2 = DNRM2 + WW(i, R)**2
      enddo

      RESID = dsqrt(DNRM2/BNRM2)

      if ( RESID .le. TOL ) exit
      if ( ITER .eq. MAXIT ) ERROR = -300

      RH01 = RH0
    enddo
!C==

```

```

Compute  $r^{(0)} = b - [A]x^{(0)}$ 
for  $i = 1, 2, \dots$ 
  solve  $[M]z^{(i-1)} = r^{(i-1)}$ 
   $\rho_{i-1} = r^{(i-1)} z^{(i-1)}$ 
  if  $i=1$ 
     $p^{(1)} = z^{(0)}$ 
  else
     $\beta_{i-1} = \rho_{i-1} / \rho_{i-2}$ 
     $p^{(i)} = z^{(i-1)} + \beta_{i-1} p^{(i-1)}$ 
  endif
   $q^{(i)} = [A]p^{(i)}$ 
   $\alpha_i = \rho_{i-1} / p^{(i)} q^{(i)}$ 
   $x^{(i)} = x^{(i-1)} + \alpha_i p^{(i)}$ 
   $r^{(i)} = r^{(i-1)} - \alpha_i q^{(i)}$ 
  check convergence  $|r|$ 
end

```

CG Solver (6/6)

```

!C
!C +-----+
!C | {x} = {x} + ALPHA*{p} |
!C | {r} = {r} - ALPHA*{q} |
!C +-----+
!C===
      do i= 1, N
          X(i) = X (i)  + ALPHA * WW(i, P)
          WW(i, R) = WW(i, R) - ALPHA * WW(i, Q)
      enddo
!C===
      DNRM2= 0. d0
      do i= 1, N
          DNRM2= DNRM2 + WW(i, R)**2
      enddo

      RESID= dsqrt(DNRM2/BNRM2)

      if ( RESID.le.TOL ) exit
      if ( ITER .eq. MAXIT ) ERROR= -300

      RHO1 = RHO
    enddo
!C===

```

```

Compute  $r^{(0)} = b - [A]x^{(0)}$ 
for  $i = 1, 2, \dots$ 
  solve  $[M]z^{(i-1)} = r^{(i-1)}$ 
   $\rho_{i-1} = r^{(i-1)} z^{(i-1)}$ 
  if  $i=1$ 
     $p^{(1)} = z^{(0)}$ 
  else
     $\beta_{i-1} = \rho_{i-1} / \rho_{i-2}$ 
     $p^{(i)} = z^{(i-1)} + \beta_{i-1} p^{(i-1)}$ 
  endif
   $q^{(i)} = [A]p^{(i)}$ 
   $\alpha_i = \rho_{i-1} / p^{(i)} q^{(i)}$ 
   $x^{(i)} = x^{(i-1)} + \alpha_i p^{(i)}$ 
   $r^{(i)} = r^{(i-1)} - \alpha_i q^{(i)}$ 
  check convergence  $|r|$ 
end

```

$$\text{Resid} = \sqrt{\frac{\text{DNorm2}}{\text{BNorm2}}} = \frac{|r|}{|b|} = \frac{|b - Ax|}{|b|} \leq \text{Tol}$$